



PARADIGM Panel System > Price Book > USA > January 2022



TABLE OF CONTENTS

SPECIFICATIONS 3

PARADIGM PANEL SYSTEM 3

GENERAL INFORMATION 3

PANELS AND COMPONENTS 4-8

ELECTRIFICATION AND CABLE MANAGEMENT 9-11

LAMINATE GALLERY PANELS 12

WORK SURFACES 12-13

SUPPORTS AND BASES 13-14

METAL STORAGE FURNITURE 15

LAMINATE STORAGE FURNITURE 15-16

PARADIGM PRICE LIST 17

MONOLITHIC PANELS 17

SEGMENTED PANELS 19

1 GLASS UPPER SEGMENT 19

1 FABRIC UPPER SEGMENT 21

1 LAMINATE UPPER SEGMENT 22

FABRIC AND GLASS UPPER SEGMENTS 23

2 FABRIC UPPER SEGMENTS 23

LAMINATE GALLERY PANELS 24

SCREENS AND STACKABLE PANELS 26

PANEL COMPONENTS 27

ELECTRICAL COMPONENTS – 3-CIRCUIT SYSTEM 29

ELECTRICAL COMPONENTS – 4-CIRCUIT SYSTEM 29

ELECTRICAL ACCESSORIES 30

WORK SURFACES WITH CABLE DROP 31

STANDARD WORK SURFACES 32

WORK SURFACE SUPPORTS 34

WORK SURFACE BASES 34

METAL STORAGE FURNITURE 35

LAMINATE STORAGE FURNITURE 36

ACCESSORIES 38



Paradigm Panel System had achieved GREENGUARD Certification.

GREENGUARD Certified products are certified to GREENGUARD standards for low chemical emissions into indoor air during product usage. For more information, visit ul.com/gg.

SPECIFICATIONS

PARADIGM PANEL SYSTEM

PARADIGM is an office furniture system that uses panels to help create workstations. Its well-thought-out, sleek components make it possible to create as wide a variety of stimulating work environments as one can imagine. Robust and modular, the system is easily reconfigurable to suit the evolving needs of the business and its users. PARADIGM's finishes can be selected to create a harmonious look with the numerous other collections of office furniture and metal storage units offered by Groupe Lacasse.

Here is how to specify a work environment

1. Divide the open area into workstations using the panels and their components.
2. Determine each user's electrical requirements.
3. Specify the surfaces and supports/legs based on the desired ergonomics of each workstation.
4. Specify the storage units according to user needs.
5. Complete the workstations with accessories.
6. Add chairs or upholstered furniture from our United Chair and Arold brands.

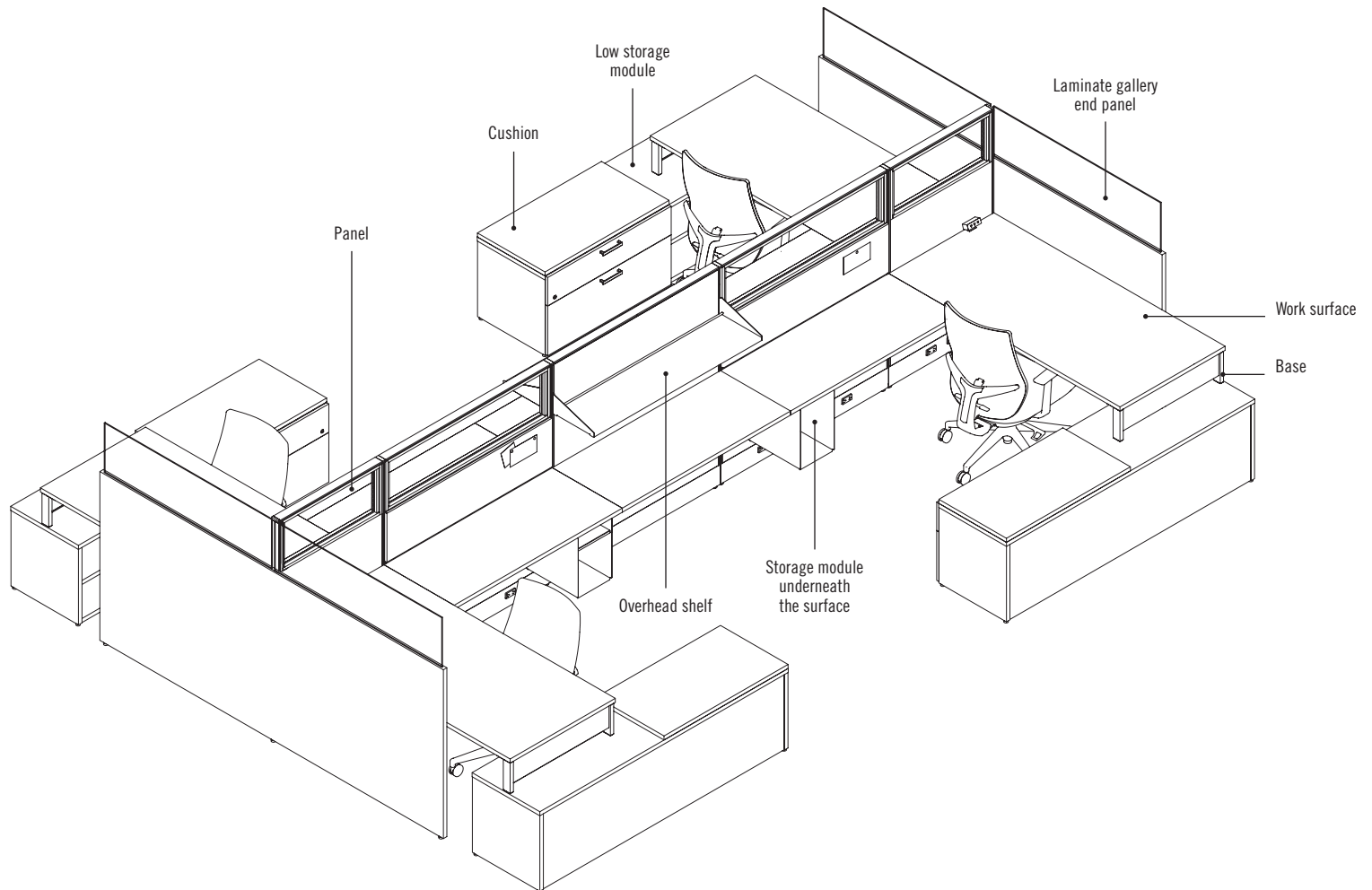

GENERAL INFORMATION

Ratings

Fire rating

- Class A fire rating.

BIFMA rating

- PARADIGM meets or exceeds the standards set by ANSI/BIFMA.

Electrical rating

- Electrical components are UL183 listed and certified for use in Canada and the United States.
- Electrical components are cUL listed.
- They meet the requirements of articles 604 and 605 of the National Electric Code (NEC/CSA /CE).

PANELS AND COMPONENTS

Panel construction – external view

- Imperial and metric dimensions are exact.
- Panels with a fabric finish can be used as tackboards.

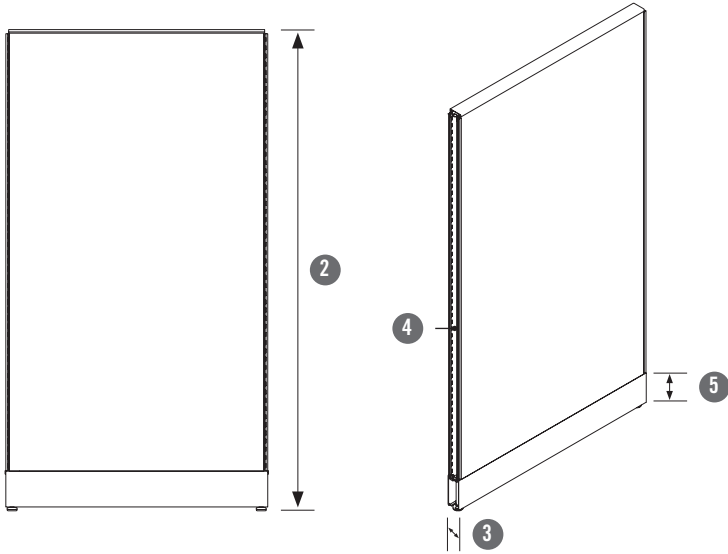

- 1 Panel width is measured from center line to center line of the in-line junction connectors. Panels are available in 24" (610 mm), 30" (762 mm), 36" (914 mm), 42" (1067 mm), 48" (1219 mm) and 60" (1524 mm) widths.
- 2 Panel height is measured from the leveler (minimum position) to the top trim. A leveler can make an adjustment of up to 2" (51 mm). Panels are available in 29 $\frac{1}{8}$ " (758 mm), 42 $\frac{1}{4}$ " (1072 mm), 48 $\frac{3}{8}$ " (1229 mm), 54 $\frac{1}{2}$ " (1386 mm) and 66 $\frac{7}{8}$ " (1700 mm) heights.
- 3 Panel thickness is 2" (51 mm).
- 4 Panels are equipped with side rails to accept work surfaces, storage modules and accessories.
- 5 The raceway is 5" (125 mm) high.



Panel construction – internal view

- Raceway covers, side rails, trims and top caps are made of painted aluminum.
- $\frac{1}{4}$ " (6 mm) tempered glass with clear or frosted finish.

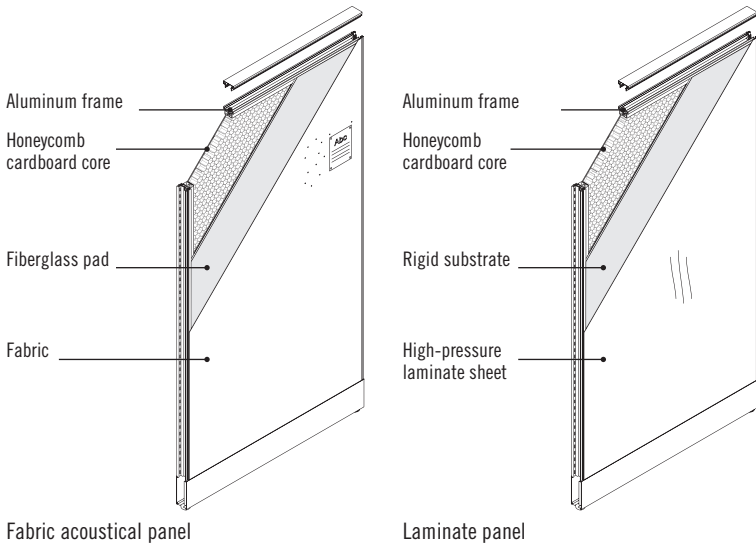

What a panel includes

Example: KPMA-6636-3P

#	Components	Qty
1	Side rails	2
2	Top trim	1
3	Junction cap	0.6*
4	Raceway covers	2
5	Glides	2
6	Alignment systems	2
7	In-line junction connector	1.6*
8	Electrical system**	1
9	Electrical connector**	0.6*

* A ratio has been established to ensure that each order comes with a sufficient number of components to allow an optimal configuration while avoiding wastefulness.

** Components included with a powered panel.

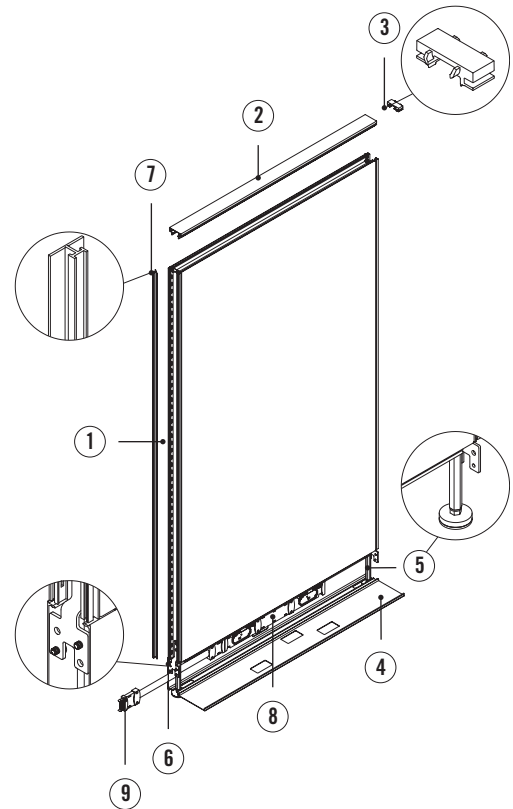

PANELS AND COMPONENTS (cont'd)

Panel dimensional range

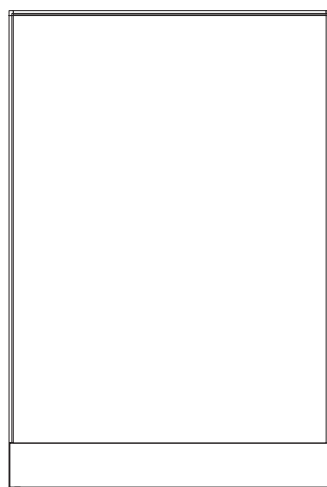
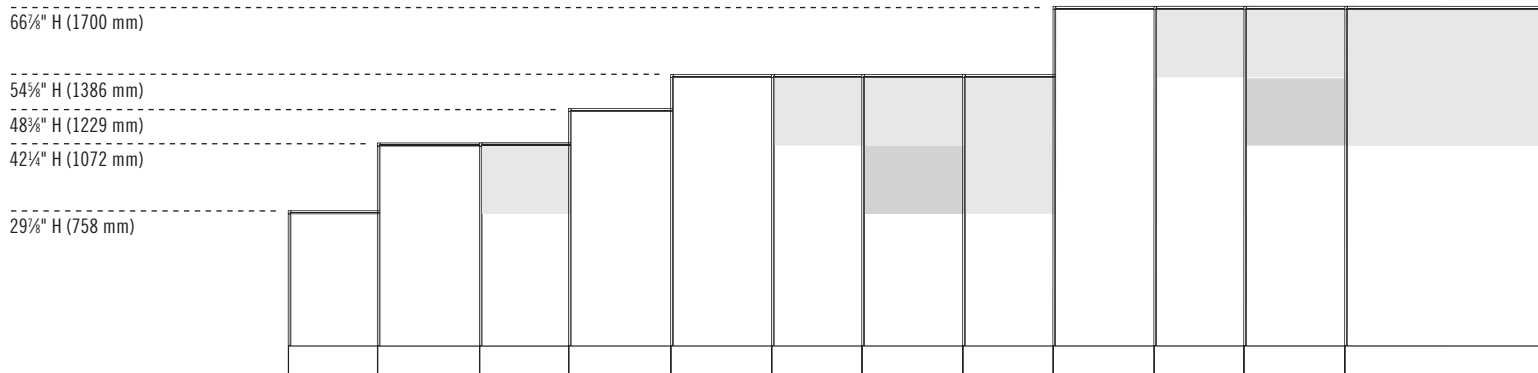

Monolithic panel

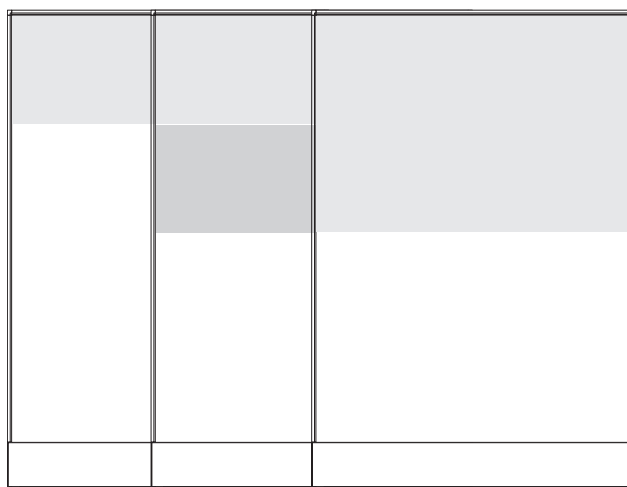

Segmented panels



Available finishes:
Fabric, laminate or glass
Upper segment 12³/₈" (314 mm) or 24³/₄" (628 mm)



Available finishes:
Fabric or laminate
Middle segment 12³/₈" (314 mm)



Available finishes:
Fabric, laminate or combined
Base

Some combinations are not available as a standard order. Contact the Special Orders department at special@groupelacasse.com.

- Segmented panels are factory-assembled.
- Different finishes can be applied on each side of a panel. Refer to the codification table (see page 17).

- A segmented panel can have only one glass segment, always positioned on the upper portion.
- The glass segment cannot support a storage unit or an accessory.

Stackable panels

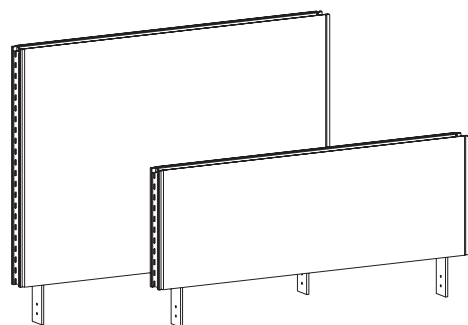

Available finishes:
Fabric, laminate,
glass or combined

- Stackable panels can be used to increase panel height if necessary during a reconfiguration.
- A stackable panel can be installed over a monolithic* or segmented panel.
- A stackable panel cannot be installed over a glass segmented panel.
- Total panel height, including stackable panels, cannot exceed 66⁷/₈" (1700 mm).
- A maximum of 2 stackable panels can be used. Their combined height cannot exceed the height of the base panel.

- A glass stackable panel cannot accept any other stackable component.
- A stackable panel cannot support any storage unit or accessory.

* 48" (1219 mm) monolithic panels can accept stackable panels. However, the height of the end-of-run trim and the junction kits must be cut at the installation job site.

PANELS AND COMPONENTS (cont'd)

Glass privacy screens for panels

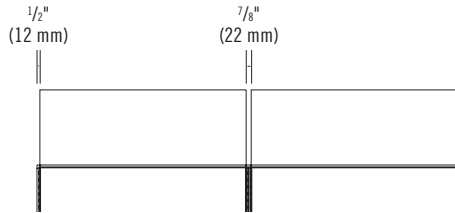
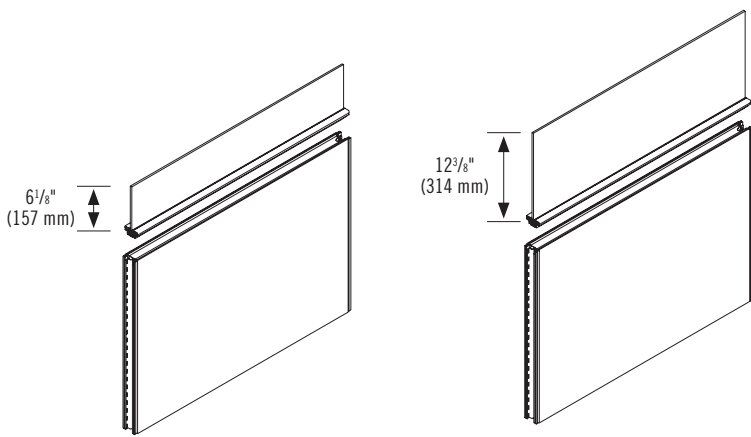
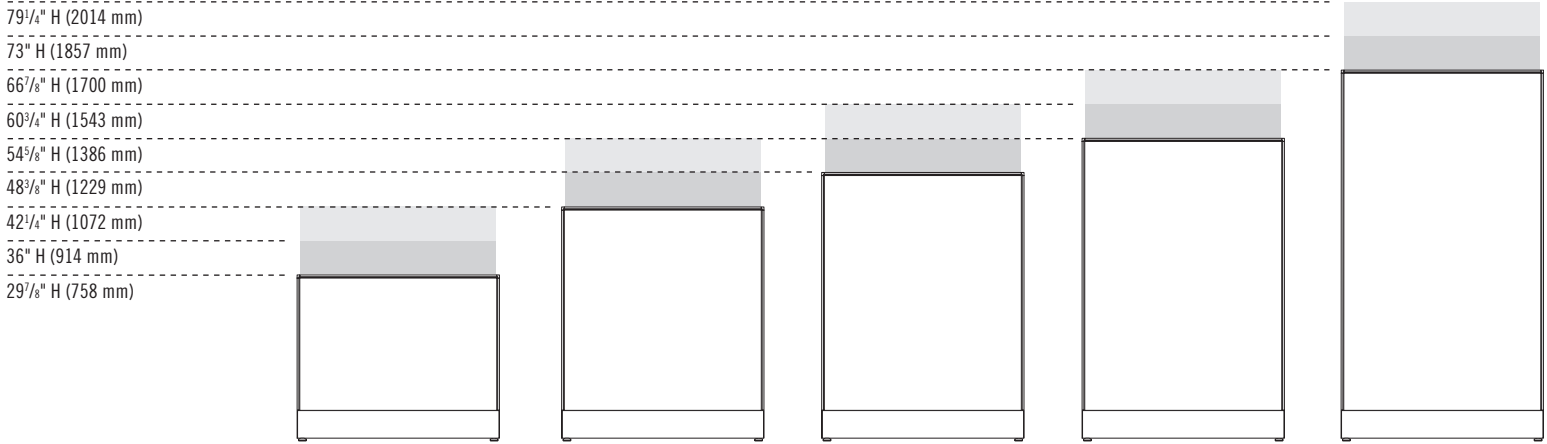

Optional alignment hardware is available to align the top of the glass privacy screens in a straight line application.

- Glass privacy screens for panels are sold with top trim.
- Available heights are 6 1/8" (157 mm) and 12 3/8" (314 mm) and enable a visual alignment with the panels.
- The screens can be installed on monolithic, segmented or stackable panels.
- A privacy screen can be installed on a panel up to 66 7/8" (1700 mm) high to reach a total height of 79 1/4" (2014 mm).
- Tempered glass privacy screens are available with clear or frosted glass 1/4" (6 mm) thick.
- Glass privacy screens cannot be installed on top of glass segments or glass stackable panels.

Junction connector applications

- Junction connectors are used to connect panels of identical or variable height.
- Junction connectors are black and are used as continuous vertical barriers between panels in order to block light.
- In-line junction connectors are included with the panels (refer to pages 17 to 24).
- 90-degree junction connectors are included in junction kits (refer to pages 27 and 28).

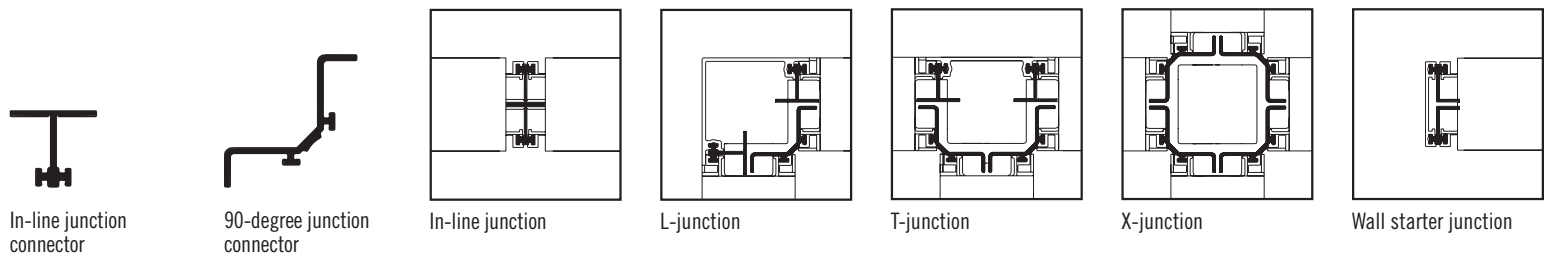

Wall starter attachment

- The wall starter is fastened in-line on the side rail using junction connectors. The footprint is thereby increased by 5/16" (8 mm).

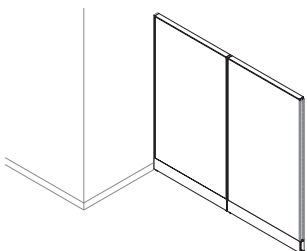

PANELS AND COMPONENTS (cont'd)

End-of-run trim

- To give the panel a finished look, it is necessary to specify an end-of-run trim.

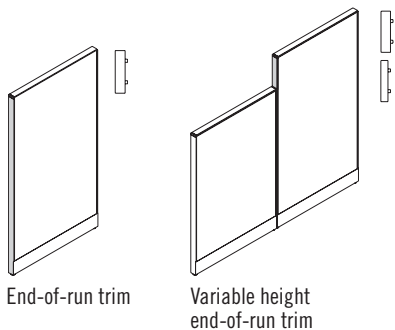

End-of-run trim

Variable height end-of-run trim

Full-height junction kits

- For standard configurations, junction kits have been designed to facilitate specification. These kits include all the components necessary to achieve the arrangements shown below.

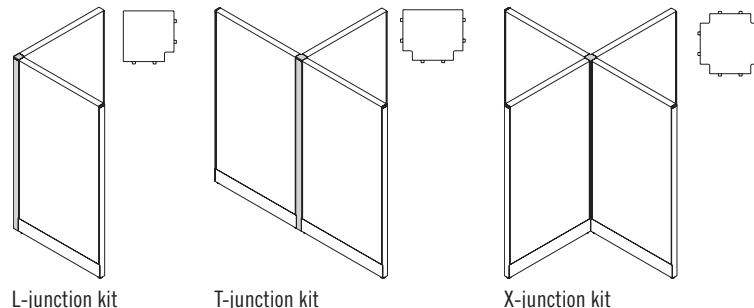

L-junction kit

T-junction kit

X-junction kit

Variable-height junction kits

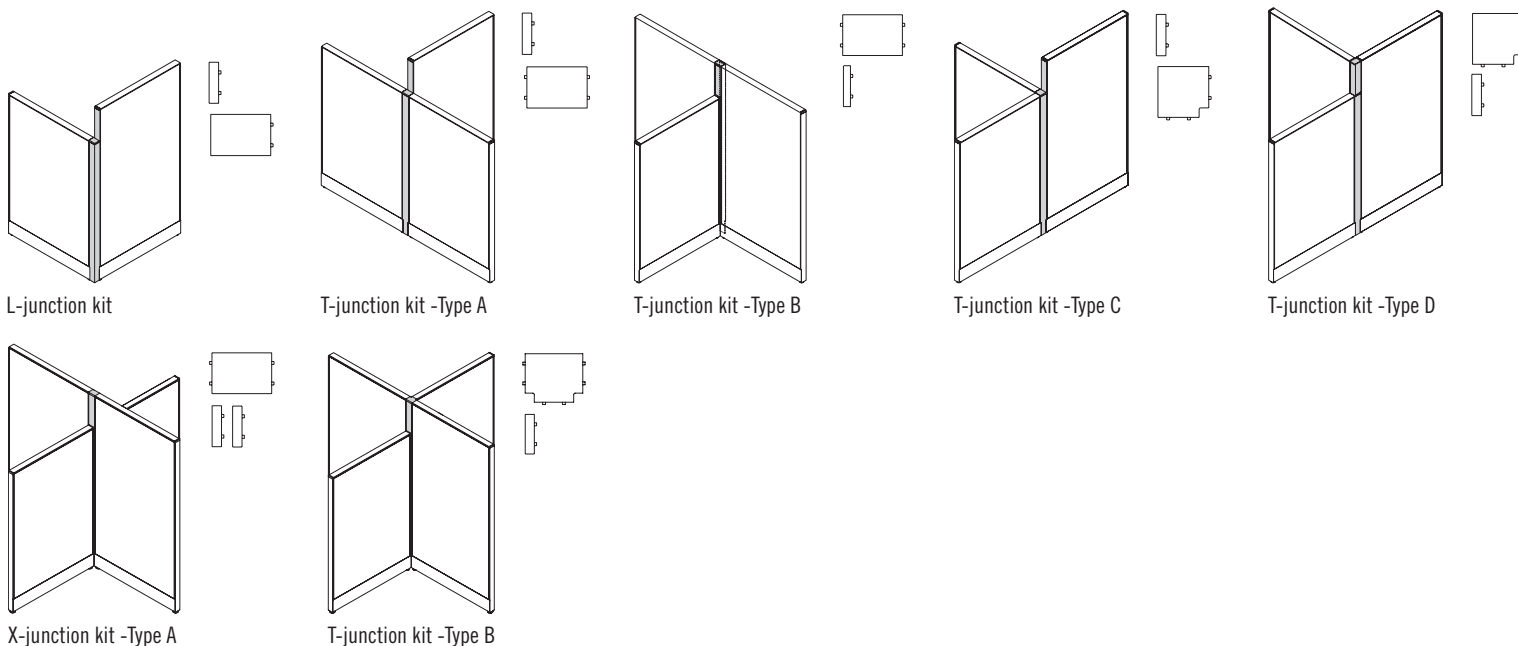

L-junction kit

T-junction kit -Type A

T-junction kit -Type B

T-junction kit -Type C

T-junction kit -Type D

X-junction kit -Type A

T-junction kit -Type B

Caps required for center-mounted hutches and transaction countertops

- A selection of caps is available to achieve a continuous, elegant look. Certain configurations with center-mounted hutches or transaction countertops will require ordering additional top caps with the appropriate junction kit. The arrangements below may also be achieved with transaction countertops.

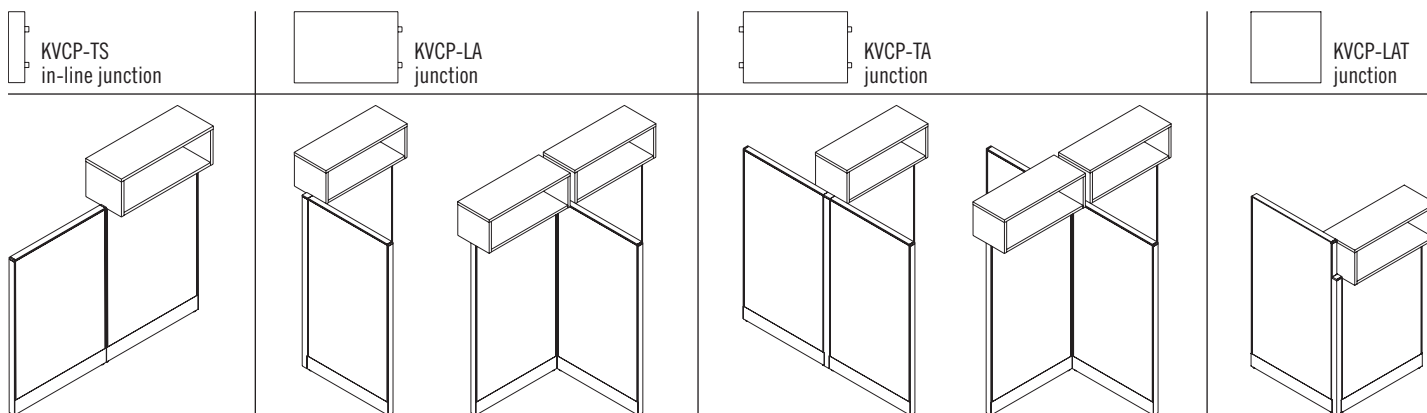

PANELS AND COMPONENTS (cont'd)

Raceway covers

- 2 raceway covers are included with a panel.
- Raceway covers can be ordered separately in order to create personalized configurations.

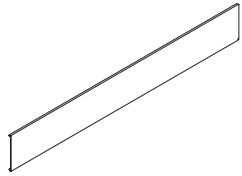

No cut-outs (N)

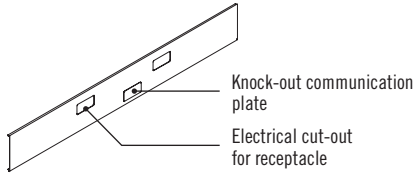

With cut-outs (P)

- The communication plate can be knocked out and is slightly off-center to enable back-to-back use of communication plates.
- Covers for electrical and communication cut-outs are available for unused cut-outs.

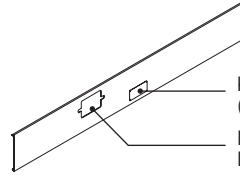

With Chicago-type cut-outs (H)

Positioning of type P cut-outs

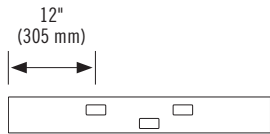

12" (305 mm)
36, 42, 48, 60" (914, 1067, 1219, 1524 mm):
2 cut-outs for receptacle and 1 knock-out communication plate

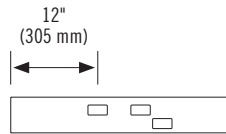

12" (305 mm)
30" (762 mm): 2 cut-outs for receptacles and 1 knock-out communication plate

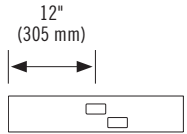

12" (305 mm)
24" (610 mm): 1 cut-out for receptacle and 1 knock-out communication plate

Positioning of type H cut-outs

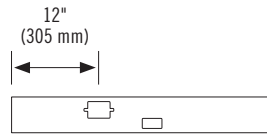

12" (305 mm)
36, 42, 48, 60" (914, 1067, 1219, 1524 mm):
1 cut-out for junction box and 1 knock-out communication plate

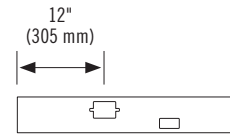

12" (305 mm)
30" (762 mm): 1 cut-out for junction box and 1 knock-out communication plate

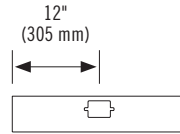

12" (305 mm)
24" (610 mm): 1 cut-out for junction box

Dimensions of cut-outs

Cut-out for receptacle and communication plate

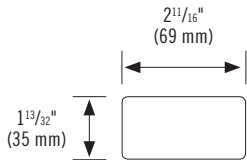

Dimensions of type H cut-outs

Cut-out for junction box

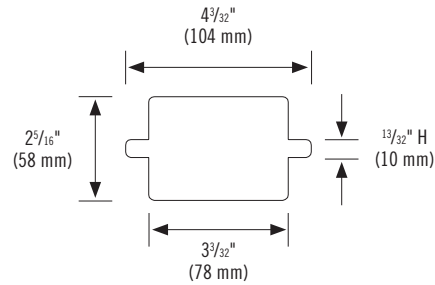

ELECTRIFICATION AND CABLE MANAGEMENT

Here are the 4 steps in order to provide electric power to a workstation

STEP 1:
Define the electrical system required as a function of needs and the number of users.

STEP 2:
Determine the power infeed.

STEP 3:
Specify the number of electrical receptacles and connectors.

STEP 4:
Complete a workstation set-up with accessories.

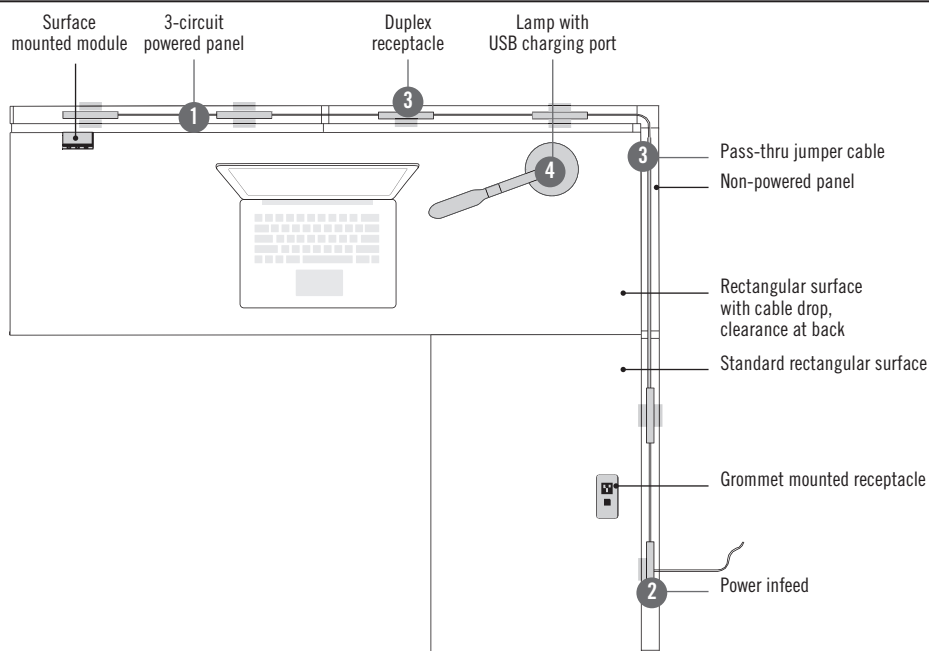

1. Define the electrical system required, according to needs and the number of users.

The choice of electrical system is based on the number of electrical and electronic devices to be plugged in at each workstation. An electrician is qualified to determine the power (amperage) used simultaneously and to recommend the best electrical system and the number of power sources required. The two electrical systems available connect only to 120 Volt / 60 Hertz power sources. Note: If the devices are in continuous use for more than 3 hours, as computers, lamps and screens generally are, it is recommended that the circuits be used at only 80% of their capacity.

3-circuit, 5-wire electrical system

The 3 circuits are common and share the same neutral wire and the same ground wire.

This modular system includes:

- 3 hot wires in 12-gauge copper.
- 1 common neutral wire in 10-gauge copper.
- 1 common ground wire in 12-gauge copper.

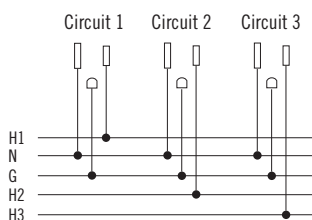

Compatible with single-phase and three-phase currents, respectively 240 / 120V, 208 / 120V.

Based on the Canadian Electrical Code (CE Code) / National Electric Code (NEC):

United States: 20-amp circuit.

- 13 receptacles and a maximum of 15 amps per circuit, for a total of 39 receptacles per power source (total capacity of 60 Amps).

Canada: 15-amp circuit.

- Maximum of 10 receptacles per circuit, for a total of 30 receptacles per power source (total capacity of 45 Amps).

If necessary or based on your needs, a 1+1 system is also available. Contact Customer Service for full details.

Important:

The electrical components for a 3-circuit, 5-wire system differ from those for a 4-circuit, 8-wire system. These components are not interchangeable from one system to the other. Accordingly, special attention is required during specification. Take note of whether the product code includes the digit '3' or '4'.

4-circuit, 8-wire electrical system

The 4th circuit is isolated and dedicated. It has its own neutral wire and ground wire.

This modular system includes:

- 4 hot wires in 12-gauge copper.
- 1 common neutral wire in 10-gauge copper.
- 1 dedicated neutral wire in 12-gauge copper.
- 2 ground wires in 12-gauge copper.

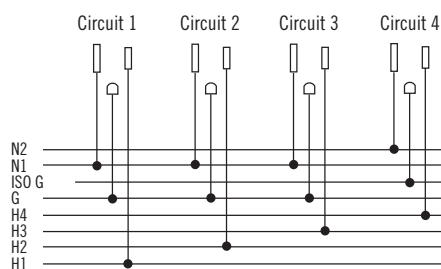

Compatible with single-phase and triple-phase currents, respectively 240 / 120V, 208 / 120V.

Based on the Canadian Electrical Code (CE Code) / National Electric Code (NEC):

United States: 20-amp circuit.

- 13 receptacles and a maximum of 15 amps per circuit, for a total of 52 receptacles per power source (total capacity of 80 Amps).

Canada: 15-amp circuit.

- Maximum of 10 receptacles per circuit, for a total of 40 receptacles per power source (total capacity of 60 Amps).

If necessary or based on your needs, a 2+2 system is also available. Contact Customer Service for full details.

ELECTRIFICATION AND CABLE MANAGEMENT (cont'd)

2. Determine the power infeed.

Floor feed

- 3 types of base feed are available.
- The infeed plugs into the receptacle location.
 - The plug protrudes by 1½" (38 mm).

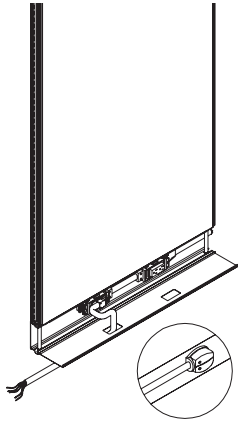

Hardwire base feed

- Plugs into the receptacle location.
- Equipped with a 72" (1829 mm) liquid tight conduit.

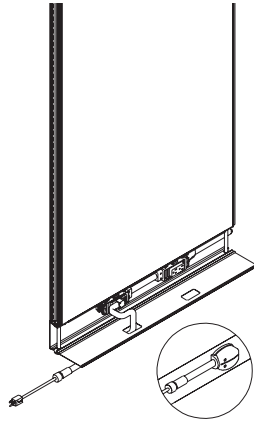

20-amp plug-in base feed

- Plugs into a receptacle.
- Equipped with a 24" (610 mm) cord.
- Powers circuit No. 1 only
- UL Recognized, cUL Approved.

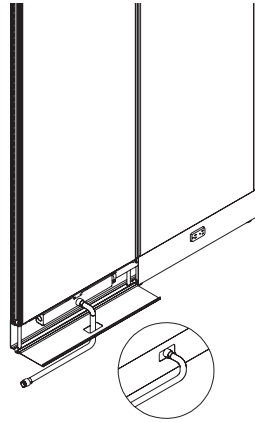

Concealed base feed

- The installation of a concealed base feed requires a non-powered panel.
- Equipped with a 72" (1829 mm) flexible metal conduit.
- Meets the standards of the New York City Building Code.
- A Type P cover can be ordered.

Ceiling feed

- The pole with electrification is equipped with a 168" (4267 mm) flexible metal conduit suitable for installation with ceilings 144" (3657 mm) high.
- The 144" (3657 mm) tall pole is used at a panel end.
- The 114" (2895 mm) tall pole is used in an LTX configuration.
- For a configuration at a panel end, the footprint increases by 2" (51 mm).
- The pole makes it possible to separate the electrical wires from the communication cables.
- The pole comes with mounting hardware for drop ceilings, for a safe installation.

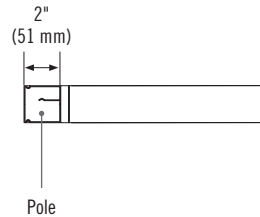

Pole

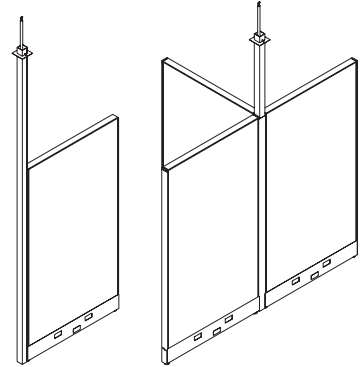

3. Specify the number of electrical receptacles and connectors.

Connectors for electrified junctions

Each powered panel comes with a power connector that enables in-line panel-to-panel connections.

Powered panels separated by a junction kit or a laminate gallery end panel require additional connectors.

Panel-to-panel connection (included with powered panel)



S-connection

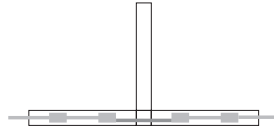

L-connection

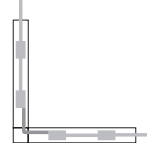

T-connection

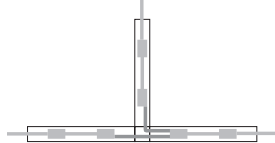

X-connection

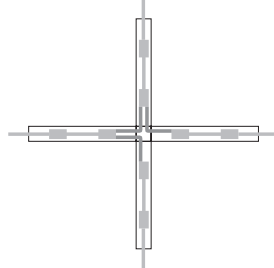

G-connection

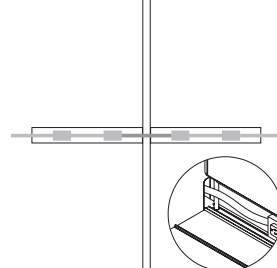

Pass-thru jumper cables for non-powered panels

When planning workstations requiring the passage of power cables through one or several non-powered panel(s), it is possible to order pass-thru jumper cables according to the electrical system chosen.



Duplex receptacles

- Each receptacle is comprised of 2 electric outlets.
- Receptacles connect to the electrical system in a tool-free installation.
- Receptacles are identified by circuit: 1 to 3, or 1 to 4, according to the electrical system chosen.
- The triangle indicates that the circuit is isolated and dedicated (4-circuit system only).
- If you are not sure what your needs are, we suggest ordering equal quantities of the receptacles for each of the circuits: C1-C2-C3-D4.

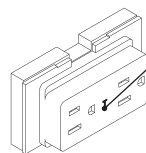

- I Circuit #1
- II Circuit #2
- III Circuit #3
- ▲ Circuit #4 isolated and dedicated

ELECTRIFICATION AND CABLE MANAGEMENT (cont'd)

4. Complete the workstation set-up with accessories.

Surface electrification

Receptacles for work surfaces are available in order to have more electrical access points.

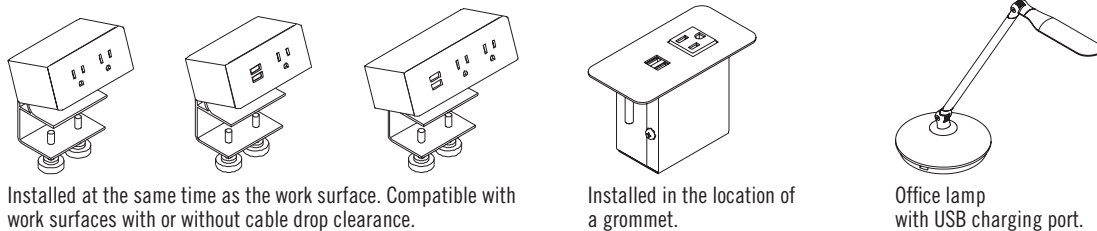

Installed at the same time as the work surface. Compatible with work surfaces with or without cable drop clearance.

Installed in the location of a grommet.

Office lamp with USB charging port.

Accessories for cable management

Cable and power management beneath the work surfaces can be done with various components:

Fastener for cable management (horizontal)

- Holds cables together beneath the work surface, for cable management.

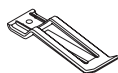

Vertical wire cover

- Enables cable management from the work surface to the floor.
- 2" (51 mm) diameter.
- With zipper.
- Black fabric.

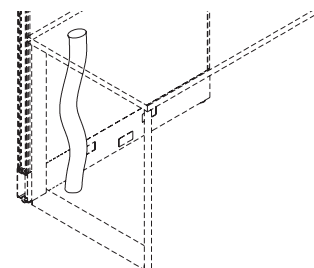

Cable capacity*

The pole and raceways have a cable capacity that varies with the cable category used.

Category 5e (cable with 0,20" (5 mm) diameter).

Category 6 (cable with 0,25" (6,35 mm) diameter).

Cable capacity with a 4-circuit system

Powered raceway

Powered pole

	60% capacity		40% capacity	
	Cat. 5e	Cat. 6	Cat. 5e	Cat. 6
Powered raceway	26	18	18	12
Powered pole	44	28	29	18

Cable capacity with a 3-circuit system

Powered raceway

Powered pole

	60% capacity		40% capacity	
	Cat. 5e	Cat. 6	Cat. 5e	Cat. 6
Powered raceway	34	21	23	14
Powered pole	44	28	29	18

Cable capacity with no electrical system

Non-powered raceway

Communication pole

	60% capacity		40% capacity	
	Cat. 5e	Cat. 6	Cat. 5e	Cat. 6
Non-powered raceway	62	50	41	33
Communication pole	44	28	29	18

Non-powered raceway

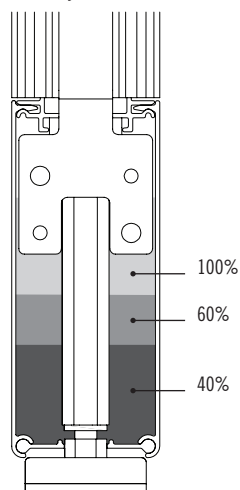

Communication pole

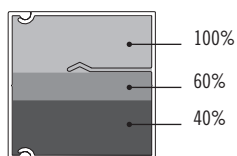

* For information purposes only. Actual cable capacity may vary according to the type of set-up and the electric modules used.

LAMINATE GALLERY PANELS

Glass privacy screens

54 $\frac{3}{8}$ " H (1386 mm)
 48 $\frac{3}{8}$ " H (1229 mm)
 42 $\frac{3}{8}$ " H (1072 mm)
 36" H (914 mm)
 29 $\frac{3}{8}$ " H (758 mm)

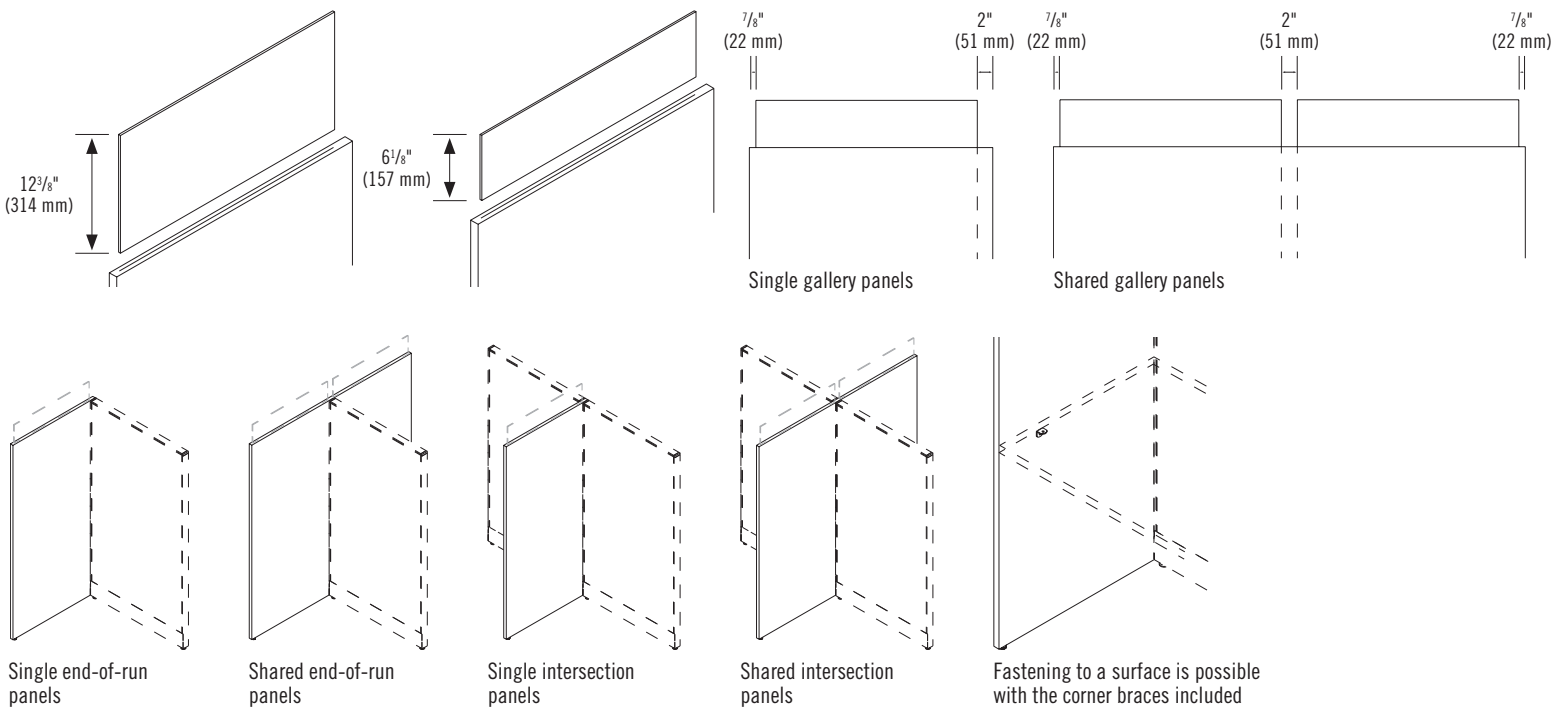

Characteristics of laminate gallery panels

- Gallery panels provide full or partial privacy when one is seated.
- They must be fastened to a monolithic or segmented panel of the same height or taller.
- A cut-out at the bottom of the laminate intersection panel makes it possible to pass power cables between two monolithic or segmented panels (refer to page 10).

- Gallery panel length includes 2" (51 mm) panel thickness.
- L-bracket included for fastening the front corner of a work surface to the gallery panel.
- Tempered glass privacy screens are available in clear or frosted glass 1/4" (6 mm) thick.

WORK SURFACES

General characteristics

- Work surfaces are made of particleboard panels finished on both sides, in mar-resistant thermofused laminate (45 lb/ft³) 1" (25 mm) thick, also known as "high-performance laminate."
- High-pressure laminate work surfaces are also available. Add 1/16" (1,5 mm) to the thickness of the work surface.
- All work surfaces are finished with ABS edgebanding in matching color.
- Work surfaces 23" (585 mm) in width or more can accept a keyboard tray.
- Monitor screen supports may be installed in a grommet location or on work surfaces that have a cable drop clearance.
- Work surfaces have metal-to-metal fittings so as to maintain product integrity during the installation or rearrangement of the cantilever supports.

Grommets and cable management

- Work surfaces may be ordered with or without grommets.
- Rectangular and corner work surfaces are also available with a 1" (25,5 mm) cable drop clearance.
- Grommets are positioned at various locations on the work surface (refer to illustration on next page).
- The plastic grommet is rectangular and silver colored.

WORK SURFACES (cont'd)

Without grommets

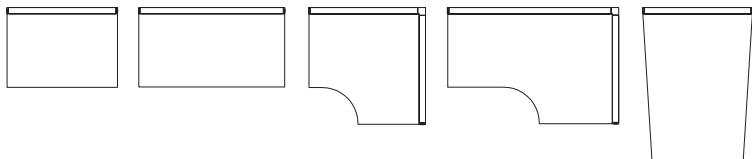

With grommets

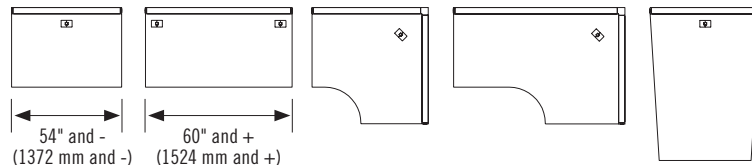

With cable drop clearance at back

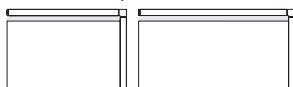

With cable drop clearance at back and on 1 side

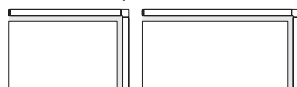

With cable drop clearance at both backs

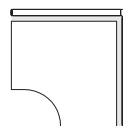

SUPPORTS AND BASES

Supports

- Supports are sold separately from work surfaces, with the exception of transaction countertops.
- Supports are coated with durable electrostatic paint.

Cantilever supports

- Left or right cantilever supports (sold as a pair) are fastened to the ends of a work surface.
- A third cantilever support, left or right, is required when the surface width exceeds 60" (1524 mm).
- They support work surfaces of all depths.
- They are compatible with work surfaces that have a cable drop clearance.
- Shared cantilever supports are installed between 2 work surfaces.
- They are made of 14-gauge steel and equipped with an anti-dislodgement device.

Corner or end brackets

- Corner or end brackets support the back of a corner work surface.
- They support the front of a work surface in order to stabilize a return panel.
- They support a rectangular or trapezoidal conference work surface whose width is identical to that of the panel.
- They support a 24" (610 mm) lower shelf of a suspended storage with drop-down door, when the lower shelf is installed on a panel of the same width.
- They support the back of a work surface when a fixed pedestal is installed.
- They are compatible with work surfaces that have a cable drop clearance.
- They are made of 14-gauge steel and equipped with an anti-dislodgement device.

Flat bracket

- Flat brackets make it possible to set up a conference work surface with another work surface.

Reinforcement bars

- A reinforcement bar is recommended for any work surface when the distance between 2 cantilevers is 48" to 60" (1219 to 1524 mm).
- A reinforcement bar is not a replacement for a support.
- The reinforcement bar supports the 24" (610 mm) lower shelf of a suspended storage with drop-down door when the lower shelf is installed on a panel with a different width.

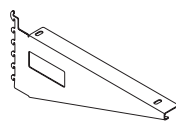

Cantilever supports

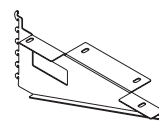

Shared cantilever support



Corner or end bracket



Flat bracket

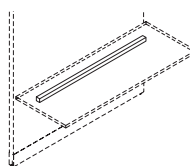

Reinforcement bar

Configuration of brackets

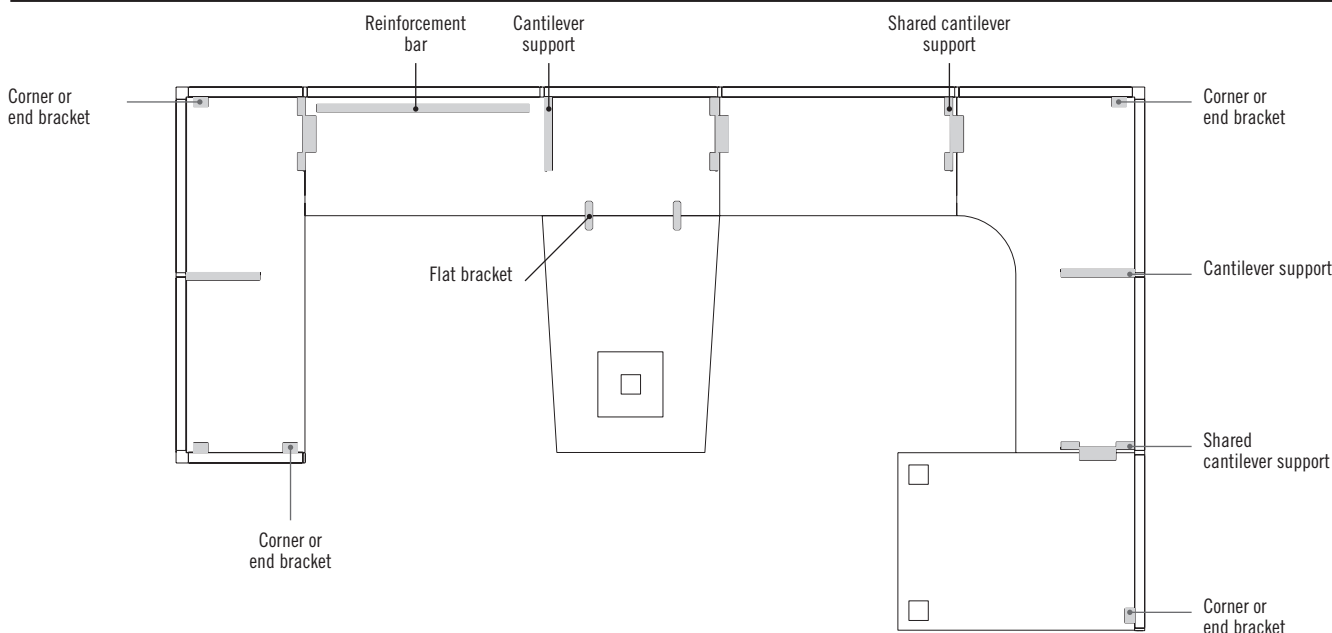

SUPPORTS AND BASES (cont'd)

End frame for panel

Different types of bases can be attached to a panel and are used to support a work surface at one end.

- 4 models available.
- P, O-metal and laminate bases allow a vertical adjustment of the panel of 1½" (38 mm).
- No adjustment is possible with the intermediate P-metal base used with a low storage unit.

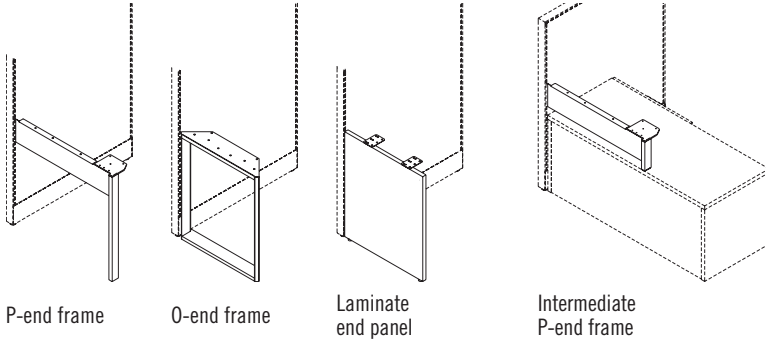

Ped-to-panel attachment filler

- Enables a full-height finish behind a modular metal pedestal.
- Available for surfaces 20" (508 mm) and 24" (610 mm) deep, according to the depth of the pedestal.

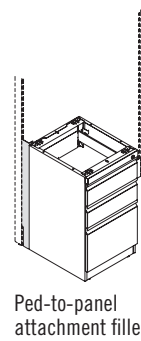

Leg/frame for surface

Different types of leg / frame make it possible to support work surfaces at their end.

- 5 models are available.
- A and O-metal frames allow a vertical adjustment of 1½" (38 mm).
- An I-leg allows a vertical adjustment of 1¼" (32 mm).
- An I-leg with a conference base allows a vertical adjustment of 1/8" (3 mm).
- No adjustment is possible with an intermediate A-metal leg used with a low storage unit.

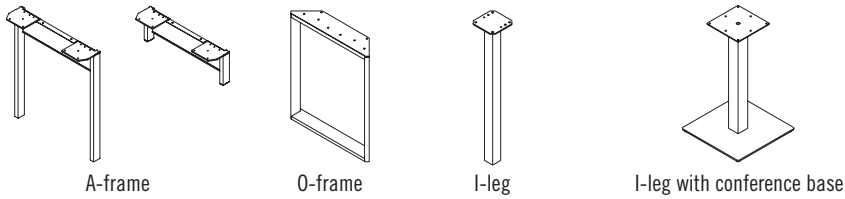

Configuration of supports

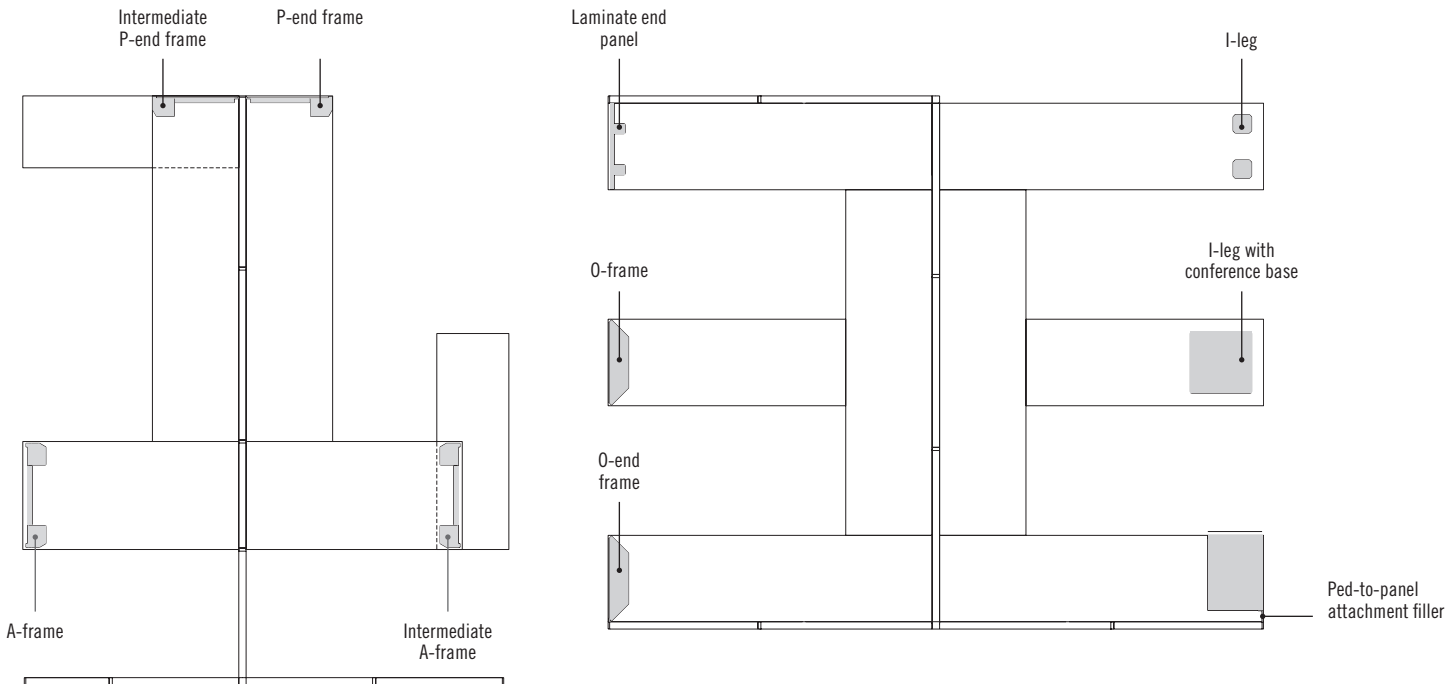

METAL STORAGE FURNITURE

Overhead shelves and units

- Suspended metal shelves and hutches are recommended for use on a panel 66⁷/₈" H (1700 mm).
- They are secured by an anti-dislodgement device.
- They can accept a lighting unit (see page 30). The unit will be completely concealed by the hutch but visible beneath a suspended shelf. For an LED lighting unit with a thin, more compact and discreet profile, see LGC-LED__ in Lacasse's General Price Book.
- Alignment supports are recommended when several metal shelves and/or hutches are installed side by side.
- Dividers are available as an option.
- These metal shelves and hutches are also available in wall-mounted versions.
- Overhead hutches designed with a laminate frame and door are also available (see page 36).

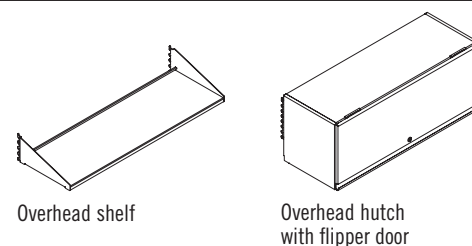

Overhead shelf

Overhead hutch with flipper door

Storage units

- A suspension bar is included in each file drawer.
- Metal front with full-width metal handles matching pedestal color.
- Optional laminate front with handles.
- Modular pedestals must be installed beneath a 29" (737 mm) work surface and combined with a corner or end support or a ped-to-panel attachment filler.
- Personal mobile storage units include a hidden drawer, an accessible compartment on the left or right or a file drawer.
- Cushions are available for the mobile pedestal and the personal mobile storage units.
- Metal storage furniture is equipped with levelers or casters and comes assembled and ready to use.
- The levelers installed on metal storage furniture allow a vertical adjustment of 1¹/₄" (32 mm).

- All metal storage furniture is equipped with a standard lock and 2 keys per lock. All locks are easily changed at the installation job site. It is possible to change the cylinders and to install a single-key system. A master key and control key are also available. Contact Customer Service for full details.

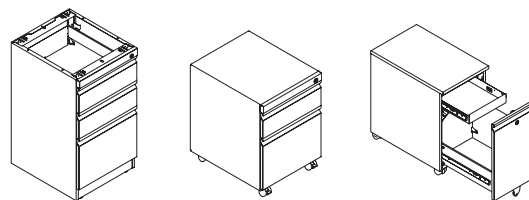

Modular pedestal

Mobile pedestal

Personal mobile storage unit

Hanging personal storage compartments

- Metal storage units can fit into one another.
- Laminate shelf available as an option.
- They must be installed beneath a work surface.
- Metal storage units can also be installed beneath an adjustable table. Contact our Special Orders department at special@groupelacasse.com.

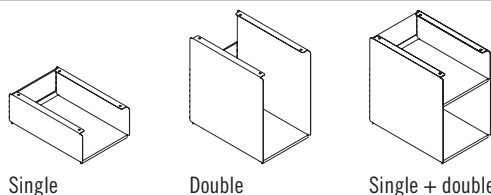

Single

Double

Single + double

LAMINATE STORAGE FURNITURE

General characteristics:

- Personal storage towers, wardrobes, storage units with lateral opening compartment and low storage units are freestanding and can be used alone.
- Levelers installed on laminate storage furniture allow a vertical adjustment of 1¹/₂" (38 mm).
- Face panels and doors cover the outer sides, the top, the base and the inset back. They provide an impeccable finish and solidity.
- All laminate storage units are equipped with a standard lock and 2 keys per lock. All locks are easily changed at the installation job site. It is possible to change the cylinders and to install a single-key system. A master key and control key are also available. Contact Customer Service for full details.

Center-mounted hutches

- Center-mounted hutches are installed to the top of a panel with 2 supports, supplied.
- They are held securely in place with an anti-dislodgement device.
- A top cap is necessary, depending on the configuration (refer to page 7).
- They are installed on panels having a maximum height of 54⁵/₈" (1386 mm).
- They cannot be installed on a stackable panel or on a segmented panel with glass.

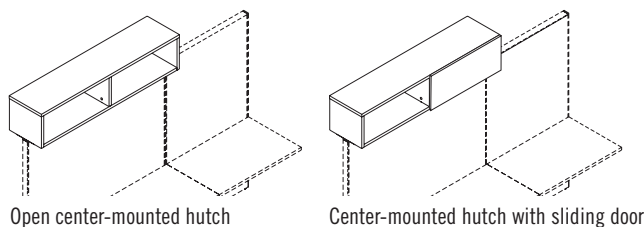

Open center-mounted hutch

Center-mounted hutch with sliding door

Height management

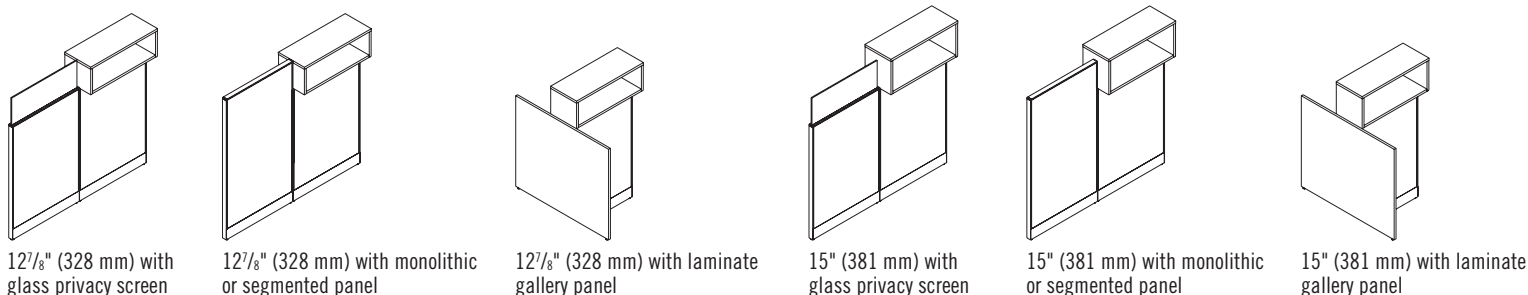

12⁷/₈" (328 mm) with glass privacy screen

12⁷/₈" (328 mm) with monolithic or segmented panel

12⁷/₈" (328 mm) with laminate gallery panel

15" (381 mm) with glass privacy screen

15" (381 mm) with monolithic or segmented panel

15" (381 mm) with laminate gallery panel

LAMINATE STORAGE FURNITURE (cont'd)

Suspended storage unit with drop-down door

- Assisted-opening, drop-down door.
- Available with choice of top or bottom shelves, for optimal set-ups in small spaces.
- Cantilevered shelves available in 12" (305 mm) or 24" (610 mm) widths.
- Suspended storage unit with a top shelf must be fastened to a work surface using the hardware included.
- We recommend not installing a work surface or a suspended storage unit with drop-down door at a height exceeding 42" (1067 mm).
- Suspended storage unit is secured in place by an anti-dislodgement device.
- The supports are located at the rear of the suspended storage unit, which must be installed on a panel of equal width, not including the width of the cantilevered shelf.
- For a suspended storage unit with drop-down door and a bottom shelf, a supplemental bracket must be ordered separately to reinforce the shelf (refer to page 13).
- **Warning:** Suspended storage units cannot be used as a seat under any circumstances.

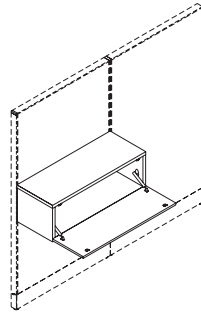

Suspended storage unit with drop-down door

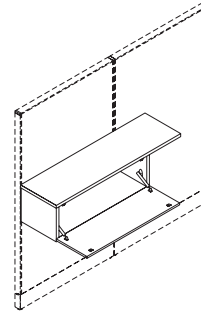

Suspended storage unit with drop-down door and upper shelf

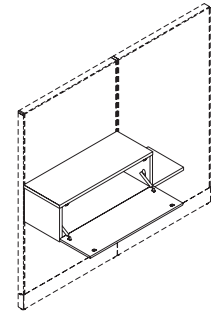

Suspended storage unit with drop-down door and lower shelf

Storage modules

- Fixed storage modules must be combined with a corner or end support in order to properly support the work surface.
- Personal storage towers, wardrobes, and storage units with lateral opening compartment may be fastened to a surface with the brackets included.
- The storage unit with lateral opening compartment has two functions: it can divide a space and be used for personal storage.

- Low storage modules can be used with an intermediate base to support a work surface.
- Cushions are available for low storage modules.

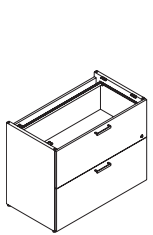

Modular lateral file

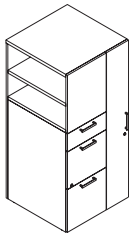

Personal storage tower

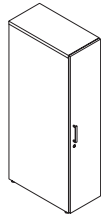

Wardrobe

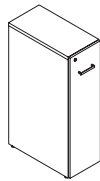

Storage unit with lateral opening compartment

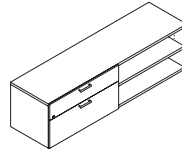
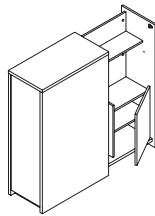

Low storage module

PANELS AND PANEL COMPONENTS

MONOLITHIC, SEGMENTED, STACKABLE PANELS AND PRIVACY SCREENS

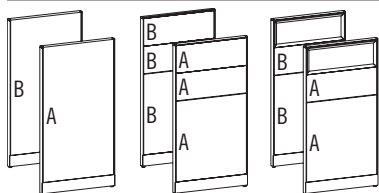

EXAMPLE: KPQLAG-6636-3P-P53-SNO-FOS-CD9-CD9-CG

A B A B

Fabric orientation: refer to swatch cards.

CODIFICATION

Series	Type of product	Finish	Panel dimension	Electrification	Finishes							
					Trim color	Panel base		Middle segment		Upper segment	Glass	
K	PM Monolithic panel	A Fabric		NN Non-powered	P53 Snow	Side A	Side B	Side A	Side B	Side A	Side B	CG Clear TG Frosted
	PQ Segmented panel 12 3/8" (314 mm)	L HPL		3P 3-circuit powered	P44 Metallic Silver							
	PH Segmented panel 24 3/4" (628 mm)	C Combined		4P 4-circuit powered	P04 Charcoal							
	PS Stackable panel	G Glass			P17 Beige							
	PF Privacy screen											

LAMINATE GALLERY PANELS

EXAMPLE: KPLESg-4238-12-L-P53-FOS-CG

CODIFICATION

Series	Type of product	Application	Type	Option	Panel dimension	Glass height	Orientation	Finishes		
								Trim color	Laminate	Glass
K	PL Laminate gallery panel	E End-of-run M Intersection	S Single D Shared	G Glass		NN None 06 6 1/8" (157 mm) 12 12 3/8" (314 mm)	L Left R Right	P53 Snow		CG Clear TG Frosted
								P44 Metallic Silver		
								P04 Charcoal P17 Beige		

W x D x H (in)	W x D x H (mm)	Code	Gr1 (\$)	Gr2 (\$)	Gr3 (\$)
----------------	----------------	------	----------	----------	----------

MONOLITHIC PANELS

Fabric acoustical panels, non-powered

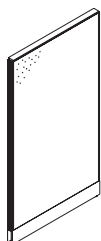

A combination of upholsteries may be applied to each side of a panel. If they are of different grades, the cost of the upholstery will be based on the price of the higher grade.

Panel includes in-line junction connectors, top trim and 2 covers with no cut-outs for the raceway.

24 x 2 x 29 7/8	610 x 51 x 758	KPMA-3024-NN-___	535	600	676
30 x 2 x 29 7/8	762 x 51 x 758	KPMA-3030-NN-___	588	653	729
36 x 2 x 29 7/8	914 x 51 x 758	KPMA-3036-NN-___	647	711	788
42 x 2 x 29 7/8	1067 x 51 x 758	KPMA-3042-NN-___	711	776	852
48 x 2 x 29 7/8	1219 x 51 x 758	KPMA-3048-NN-___	782	847	923
60 x 2 x 29 7/8	1524 x 51 x 758	KPMA-3060-NN-___	899	964	1,040
24 x 2 x 42 1/4	610 x 51 x 1072	KPMA-4224-NN-___	577	641	718
30 x 2 x 42 1/4	762 x 51 x 1072	KPMA-4230-NN-___	641	706	782
36 x 2 x 42 1/4	914 x 51 x 1072	KPMA-4236-NN-___	700	765	841
42 x 2 x 42 1/4	1067 x 51 x 1072	KPMA-4242-NN-___	771	836	912
48 x 2 x 42 1/4	1219 x 51 x 1072	KPMA-4248-NN-___	847	912	988
60 x 2 x 42 1/4	1524 x 51 x 1072	KPMA-4260-NN-___	977	1,040	1,118
24 x 2 x 48 3/8	610 x 51 x 1229	KPMA-4824-NN-___	606	671	747
30 x 2 x 48 3/8	762 x 51 x 1229	KPMA-4830-NN-___	664	729	805
36 x 2 x 48 3/8	914 x 51 x 1229	KPMA-4836-NN-___	735	800	876
42 x 2 x 48 3/8	1067 x 51 x 1229	KPMA-4842-NN-___	805	870	946
48 x 2 x 48 3/8	1219 x 51 x 1229	KPMA-4848-NN-___	883	946	1,024
60 x 2 x 48 3/8	1524 x 51 x 1229	KPMA-4860-NN-___	1,017	1,082	1,158
24 x 2 x 54 5/8	610 x 51 x 1386	KPMA-5424-NN-___	653	718	794
30 x 2 x 54 5/8	762 x 51 x 1386	KPMA-5430-NN-___	718	782	859
36 x 2 x 54 5/8	914 x 51 x 1386	KPMA-5436-NN-___	794	859	935
42 x 2 x 54 5/8	1067 x 51 x 1386	KPMA-5442-NN-___	870	935	1,011
48 x 2 x 54 5/8	1219 x 51 x 1386	KPMA-5448-NN-___	953	1,017	1,094
60 x 2 x 54 5/8	1524 x 51 x 1386	KPMA-5460-NN-___	1,094	1,158	1,235
24 x 2 x 66 7/8	610 x 51 x 1700	KPMA-6624-NN-___	700	765	841
30 x 2 x 66 7/8	762 x 51 x 1700	KPMA-6630-NN-___	771	836	912
36 x 2 x 66 7/8	914 x 51 x 1700	KPMA-6636-NN-___	847	912	988
42 x 2 x 66 7/8	1067 x 51 x 1700	KPMA-6642-NN-___	935	1,000	1,076
48 x 2 x 66 7/8	1219 x 51 x 1700	KPMA-6648-NN-___	1,029	1,094	1,170
60 x 2 x 66 7/8	1524 x 51 x 1700	KPMA-6660-NN-___	1,176	1,241	1,317

At the end of the product code add, in this order: trim color, upholstery for sides A/B.

Fabric acoustical panels, powered



A combination of upholsteries may be applied to each side of a panel. If they are of different grades, the cost of the upholstery will be based on the price of the higher grade.

W x D x H (in)	W x D x H (mm)	Code	Gr1 (\$)	Gr2 (\$)	Gr3 (\$)
----------------	----------------	------	----------	----------	----------

Panel includes in-line junction connectors, top trim, 2 covers with cut-outs and knock-out communication plates for the raceway, the electric system, and the in-line power connector. To be ordered separately: duplex receptacles KER - - -; refer to pages 29 and 30.

24 x 2 x 29 7/8	610 x 51 x 758	KPMA-3024-P-___	659	724	800
30 x 2 x 29 7/8	762 x 51 x 758	KPMA-3030-P-___	741	805	883
36 x 2 x 29 7/8	914 x 51 x 758	KPMA-3036-P-___	818	883	959
42 x 2 x 29 7/8	1067 x 51 x 758	KPMA-3042-P-___	883	946	1,024
48 x 2 x 29 7/8	1219 x 51 x 758	KPMA-3048-P-___	964	1,029	1,105
60 x 2 x 29 7/8	1524 x 51 x 758	KPMA-3060-P-___	1,135	1,200	1,276
24 x 2 x 42 1/4	610 x 51 x 1072	KPMA-4224-P-___	706	771	847
30 x 2 x 42 1/4	762 x 51 x 1072	KPMA-4230-P-___	794	859	935
36 x 2 x 42 1/4	914 x 51 x 1072	KPMA-4236-P-___	876	941	1,017
42 x 2 x 42 1/4	1067 x 51 x 1072	KPMA-4242-P-___	946	1,011	1,088
48 x 2 x 42 1/4	1219 x 51 x 1072	KPMA-4248-P-___	1,029	1,094	1,170
60 x 2 x 42 1/4	1524 x 51 x 1072	KPMA-4260-P-___	1,217	1,282	1,359
24 x 2 x 48 3/8	610 x 51 x 1229	KPMA-4824-P-___	729	794	870
30 x 2 x 48 3/8	762 x 51 x 1229	KPMA-4830-P-___	823	888	964
36 x 2 x 48 3/8	914 x 51 x 1229	KPMA-4836-P-___	906	970	1,047
42 x 2 x 48 3/8	1067 x 51 x 1229	KPMA-4842-P-___	977	1,040	1,118
48 x 2 x 48 3/8	1219 x 51 x 1229	KPMA-4848-P-___	1,064	1,129	1,205
60 x 2 x 48 3/8	1524 x 51 x 1229	KPMA-4860-P-___	1,252	1,317	1,393
24 x 2 x 54 5/8	610 x 51 x 1386	KPMA-5424-P-___	776	841	917
30 x 2 x 54 5/8	762 x 51 x 1386	KPMA-5430-P-___	876	941	1,017
36 x 2 x 54 5/8	914 x 51 x 1386	KPMA-5436-P-___	964	1,029	1,105
42 x 2 x 54 5/8	1067 x 51 x 1386	KPMA-5442-P-___	1,047	1,111	1,188
48 x 2 x 54 5/8	1219 x 51 x 1386	KPMA-5448-P-___	1,135	1,200	1,276
60 x 2 x 54 5/8	1524 x 51 x 1386	KPMA-5460-P-___	1,335	1,400	1,476
24 x 2 x 66 7/8	610 x 51 x 1700	KPMA-6624-P-___	829	894	970
30 x 2 x 66 7/8	762 x 51 x 1700	KPMA-6630-P-___	930	993	1,071
36 x 2 x 66 7/8	914 x 51 x 1700	KPMA-6636-P-___	1,024	1,088	1,165
42 x 2 x 66 7/8	1067 x 51 x 1700	KPMA-6642-P-___	1,111	1,176	1,252
48 x 2 x 66 7/8	1219 x 51 x 1700	KPMA-6648-P-___	1,205	1,270	1,346
60 x 2 x 66 7/8	1524 x 51 x 1700	KPMA-6660-P-___	1,417	1,482	1,558

Specify 3-circuit or 4-circuit system (surcharge of \$130 for 4-circuit). At the end of the product code add, in this order: trim color, upholstery for sides A/B.

Laminate panels, non-powered



A combination of HPL finishes may be applied to each side of a panel.

W x D x H (in)	W x D x H (mm)	Code	Price (\$)
<i>Panel includes in-line junction connectors, top trim and 2 covers with no cut-outs for raceway.</i>			
24 x 2 x 29 ⁷ / ₈	610 x 51 x 758	KPML-3024-NN-___	906
30 x 2 x 29 ⁷ / ₈	762 x 51 x 758	KPML-3030-NN-___	949
36 x 2 x 29 ⁷ / ₈	914 x 51 x 758	KPML-3036-NN-___	992
42 x 2 x 29 ⁷ / ₈	1067 x 51 x 758	KPML-3042-NN-___	1,133
48 x 2 x 29 ⁷ / ₈	1219 x 51 x 758	KPML-3048-NN-___	1,177
24 x 2 x 42 ¹ / ₄	610 x 51 x 1072	KPML-4224-NN-___	1,029
30 x 2 x 42 ¹ / ₄	762 x 51 x 1072	KPML-4230-NN-___	1,072
36 x 2 x 42 ¹ / ₄	914 x 51 x 1072	KPML-4236-NN-___	1,116
42 x 2 x 42 ¹ / ₄	1067 x 51 x 1072	KPML-4242-NN-___	1,318
48 x 2 x 42 ¹ / ₄	1219 x 51 x 1072	KPML-4248-NN-___	1,362
24 x 2 x 48 ³ / ₈	610 x 51 x 1229	KPML-4824-NN-___	1,091
30 x 2 x 48 ³ / ₈	762 x 51 x 1229	KPML-4830-NN-___	1,133
36 x 2 x 48 ³ / ₈	914 x 51 x 1229	KPML-4836-NN-___	1,183
42 x 2 x 48 ³ / ₈	1067 x 51 x 1229	KPML-4842-NN-___	1,411
48 x 2 x 48 ³ / ₈	1219 x 51 x 1229	KPML-4848-NN-___	1,454
24 x 2 x 54 ³ / ₈	610 x 51 x 1386	KPML-5424-NN-___	1,152
30 x 2 x 54 ³ / ₈	762 x 51 x 1386	KPML-5430-NN-___	1,202
36 x 2 x 54 ³ / ₈	914 x 51 x 1386	KPML-5436-NN-___	1,244
42 x 2 x 54 ³ / ₈	1067 x 51 x 1386	KPML-5442-NN-___	1,503
48 x 2 x 54 ³ / ₈	1219 x 51 x 1386	KPML-5448-NN-___	1,547
24 x 2 x 66 ⁷ / ₈	610 x 51 x 1700	KPML-6624-NN-___	1,183
30 x 2 x 66 ⁷ / ₈	762 x 51 x 1700	KPML-6630-NN-___	1,226
36 x 2 x 66 ⁷ / ₈	914 x 51 x 1700	KPML-6636-NN-___	1,269
42 x 2 x 66 ⁷ / ₈	1067 x 51 x 1700	KPML-6642-NN-___	1,559
48 x 2 x 66 ⁷ / ₈	1219 x 51 x 1700	KPML-6648-NN-___	1,602

At the end of the product code add, in this order: trim color, HPL finishes for sides A/B.

Laminate panels, powered



A combination of HPL finishes may be applied to each side of a panel.

W x D x H (in)	W x D x H (mm)	Code	Price (\$)
<i>Panel includes in-line junction connectors, top trim, 2 covers with cut-outs and knock-out communication plates for the raceway, the electric system, and the in-line power connector. To be ordered separately: duplex receptacles KER - - - -; refer to pages 29 and 30.</i>			
24 x 2 x 29 ⁷ / ₈	610 x 51 x 758	KPML-3024- P-___	1,035
30 x 2 x 29 ⁷ / ₈	762 x 51 x 758	KPML-3030- P-___	1,109
36 x 2 x 29 ⁷ / ₈	914 x 51 x 758	KPML-3036- P-___	1,170
42 x 2 x 29 ⁷ / ₈	1067 x 51 x 758	KPML-3042- P-___	1,313
48 x 2 x 29 ⁷ / ₈	1219 x 51 x 758	KPML-3048- P-___	1,368
24 x 2 x 42 ¹ / ₄	610 x 51 x 1072	KPML-4224- P-___	1,158
30 x 2 x 42 ¹ / ₄	762 x 51 x 1072	KPML-4230- P-___	1,232
36 x 2 x 42 ¹ / ₄	914 x 51 x 1072	KPML-4236- P-___	1,294
42 x 2 x 42 ¹ / ₄	1067 x 51 x 1072	KPML-4242- P-___	1,497
48 x 2 x 42 ¹ / ₄	1219 x 51 x 1072	KPML-4248- P-___	1,552
24 x 2 x 48 ³ / ₈	610 x 51 x 1229	KPML-4824- P-___	1,220
30 x 2 x 48 ³ / ₈	762 x 51 x 1229	KPML-4830- P-___	1,294
36 x 2 x 48 ³ / ₈	914 x 51 x 1229	KPML-4836- P-___	1,362
42 x 2 x 48 ³ / ₈	1067 x 51 x 1229	KPML-4842- P-___	1,589
48 x 2 x 48 ³ / ₈	1219 x 51 x 1229	KPML-4848- P-___	1,645
24 x 2 x 54 ³ / ₈	610 x 51 x 1386	KPML-5424- P-___	1,281
30 x 2 x 54 ³ / ₈	762 x 51 x 1386	KPML-5430- P-___	1,362
36 x 2 x 54 ³ / ₈	914 x 51 x 1386	KPML-5436- P-___	1,424
42 x 2 x 54 ³ / ₈	1067 x 51 x 1386	KPML-5442- P-___	1,682
48 x 2 x 54 ³ / ₈	1219 x 51 x 1386	KPML-5448- P-___	1,737
24 x 2 x 66 ⁷ / ₈	610 x 51 x 1700	KPML-6624- P-___	1,313
30 x 2 x 66 ⁷ / ₈	762 x 51 x 1700	KPML-6630- P-___	1,387
36 x 2 x 66 ⁷ / ₈	914 x 51 x 1700	KPML-6636- P-___	1,448
42 x 2 x 66 ⁷ / ₈	1067 x 51 x 1700	KPML-6642- P-___	1,737
48 x 2 x 66 ⁷ / ₈	1219 x 51 x 1700	KPML-6648- P-___	1,793

Specify 3-circuit or 4-circuit system (surcharge of \$130 for 4-circuit).

At the end of the product code add, in this order: trim color, HPL finishes for sides A/B.

Laminate/fabric combined panels, non-powered



W x D x H (in)	W x D x H (mm)	Code	Gr1 (\$)	Gr2 (\$)	Gr3 (\$)
<i>Panel includes in-line junction connectors, top trim and 2 covers with no cut-outs for raceway.</i>					
24 x 2 x 29 ⁷ / ₈	610 x 51 x 758	KPMC-3024-NN-___	818	852	894
30 x 2 x 29 ⁷ / ₈	762 x 51 x 758	KPMC-3030-NN-___	870	906	946
36 x 2 x 29 ⁷ / ₈	914 x 51 x 758	KPMC-3036-NN-___	917	953	993
42 x 2 x 29 ⁷ / ₈	1067 x 51 x 758	KPMC-3042-NN-___	1,017	1,053	1,094
48 x 2 x 29 ⁷ / ₈	1219 x 51 x 758	KPMC-3048-NN-___	1,064	1,100	1,141
24 x 2 x 42 ¹ / ₄	610 x 51 x 1072	KPMC-4224-NN-___	930	964	1,006
30 x 2 x 42 ¹ / ₄	762 x 51 x 1072	KPMC-4230-NN-___	982	1,017	1,058
36 x 2 x 42 ¹ / ₄	914 x 51 x 1072	KPMC-4236-NN-___	1,035	1,071	1,111
42 x 2 x 42 ¹ / ₄	1067 x 51 x 1072	KPMC-4242-NN-___	1,158	1,194	1,235
48 x 2 x 42 ¹ / ₄	1219 x 51 x 1072	KPMC-4248-NN-___	1,205	1,241	1,282
24 x 2 x 48 ³ / ₈	610 x 51 x 1229	KPMC-4824-NN-___	988	1,024	1,064
30 x 2 x 48 ³ / ₈	762 x 51 x 1229	KPMC-4830-NN-___	1,040	1,076	1,118
36 x 2 x 48 ³ / ₈	914 x 51 x 1229	KPMC-4836-NN-___	1,088	1,123	1,165
42 x 2 x 48 ³ / ₈	1067 x 51 x 1229	KPMC-4842-NN-___	1,229	1,264	1,306
48 x 2 x 48 ³ / ₈	1219 x 51 x 1229	KPMC-4848-NN-___	1,276	1,312	1,353
24 x 2 x 54 ³ / ₈	610 x 51 x 1386	KPMC-5424-NN-___	1,047	1,082	1,123
30 x 2 x 54 ³ / ₈	762 x 51 x 1386	KPMC-5430-NN-___	1,094	1,129	1,170
36 x 2 x 54 ³ / ₈	914 x 51 x 1386	KPMC-5436-NN-___	1,147	1,182	1,223
42 x 2 x 54 ³ / ₈	1067 x 51 x 1386	KPMC-5442-NN-___	1,299	1,335	1,376
48 x 2 x 54 ³ / ₈	1219 x 51 x 1386	KPMC-5448-NN-___	1,353	1,388	1,429
24 x 2 x 66 ⁷ / ₈	610 x 51 x 1700	KPMC-6624-NN-___	1,158	1,194	1,235
30 x 2 x 66 ⁷ / ₈	762 x 51 x 1700	KPMC-6630-NN-___	1,205	1,241	1,282
36 x 2 x 66 ⁷ / ₈	914 x 51 x 1700	KPMC-6636-NN-___	1,259	1,294	1,335
42 x 2 x 66 ⁷ / ₈	1067 x 51 x 1700	KPMC-6642-NN-___	1,440	1,476	1,518
48 x 2 x 66 ⁷ / ₈	1219 x 51 x 1700	KPMC-6648-NN-___	1,494	1,529	1,570

At the end of the product code add, in this order: trim color, HPL finish for side A, upholstery for side B.

Laminate/fabric combined panels, powered

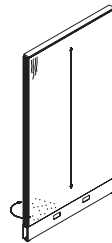

W x D x H (in)	W x D x H (mm)	Code	Gr1 (\$)	Gr2 (\$)	Gr3 (\$)
<i>Panel includes in-line junction connectors, top trim, 2 covers with cut-outs and knock-out communication plates for the raceway, the electric system, and the in-line power connector. To be ordered separately: duplex receptacles KER - - - -; refer to pages 29 and 30.</i>					
24 x 2 x 29 ⁷ / ₈	610 x 51 x 758	KPMC-3024- P-___	941	977	1,017
30 x 2 x 29 ⁷ / ₈	762 x 51 x 758	KPMC-3030- P-___	1,024	1,058	1,100
36 x 2 x 29 ⁷ / ₈	914 x 51 x 758	KPMC-3036- P-___	1,088	1,123	1,165
42 x 2 x 29 ⁷ / ₈	1067 x 51 x 758	KPMC-3042- P-___	1,188	1,223	1,264
48 x 2 x 29 ⁷ / ₈	1219 x 51 x 758	KPMC-3048- P-___	1,247	1,282	1,323
24 x 2 x 42 ¹ / ₄	610 x 51 x 1072	KPMC-4224- P-___	1,053	1,088	1,129
30 x 2 x 42 ¹ / ₄	762 x 51 x 1072	KPMC-4230- P-___	1,135	1,170	1,212
36 x 2 x 42 ¹ / ₄	914 x 51 x 1072	KPMC-4236- P-___	1,205	1,241	1,282
42 x 2 x 42 ¹ / ₄	1067 x 51 x 1072	KPMC-4242- P-___	1,329	1,364	1,406
48 x 2 x 42 ¹ / ₄	1219 x 51 x 1072	KPMC-4248- P-___	1,388	1,424	1,464
24 x 2 x 48 ³ / ₈	610 x 51 x 1229	KPMC-4824- P-___	1,111	1,147	1,188
30 x 2 x 48 ³ / ₈	762 x 51 x 1229	KPMC-4830- P-___	1,194	1,229	1,270
36 x 2 x 48 ³ / ₈	914 x 51 x 1229	KPMC-4836- P-___	1,259	1,294	1,335
42 x 2 x 48 ³ / ₈	1067 x 51 x 1229	KPMC-4842- P-___	1,400	1,435	1,476
48 x 2 x 48 ³ / ₈	1219 x 51 x 1229	KPMC-4848- P-___	1,458	1,494	1,534
24 x 2 x 54 ³ / ₈	610 x 51 x 1386	KPMC-5424- P-___	1,170	1,205	1,247
30 x 2 x 54 ³ / ₈	762 x 51 x 1386	KPMC-5430- P-___	1,247	1,282	1,323
36 x 2 x 54 ³ / ₈	914 x 51 x 1386	KPMC-5436- P-___	1,317	1,353	1,393
42 x 2 x 54 ³ / ₈	1067 x 51 x 1386	KPMC-5442- P-___	1,471	1,505	1,547
48 x 2 x 54 ³ / ₈	1219 x 51 x 1386	KPMC-5448- P-___	1,534	1,570	1,612
24 x 2 x 66 ⁷ / ₈	610 x 51 x 1700	KPMC-6624- P-___	1,282	1,317	1,359
30 x 2 x 66 ⁷ / ₈	762 x 51 x 1700	KPMC-6630- P-___	1,359	1,393	1,435
36 x 2 x 66 ⁷ / ₈	914 x 51 x 1700	KPMC-6636- P-___	1,429	1,464	1,505
42 x 2 x 66 ⁷ / ₈	1067 x 51 x 1700	KPMC-6642- P-___	1,612	1,646	1,688
48 x 2 x 66 ⁷ / ₈	1219 x 51 x 1700	KPMC-6648- P-___	1,676	1,711	1,753

Specify 3-circuit or 4-circuit system (surcharge of \$130 for 4-circuit). At the end of the product code add, in this order: trim color, HPL finish for side A, upholstery for side B.

	W x D x H (in)	W x D x H (mm)	Code	Gr1 (\$)	Gr2 (\$)	Gr3 (\$)
SEGMENTED PANELS – 1 GLASS UPPER SEGMENT						
Fabric acoustical panels, 12 3/8" H glass segment, non-powered	<i>Panel includes the tempered glass segment, in-line junction connectors, top trim and 2 covers with no cut-outs for raceway.</i>					
	24 x 2 x 42 1/4	610 x 51 x 1072	KPQAG-4224-NN	1,158	1,223	1,299
	30 x 2 x 42 1/4	762 x 51 x 1072	KPQAG-4230-NN	1,252	1,317	1,393
	36 x 2 x 42 1/4	914 x 51 x 1072	KPQAG-4236-NN	1,364	1,429	1,505
	42 x 2 x 42 1/4	1067 x 51 x 1072	KPQAG-4242-NN	1,476	1,541	1,617
	48 x 2 x 42 1/4	1219 x 51 x 1072	KPQAG-4248-NN	1,605	1,670	1,746
	60 x 2 x 42 1/4	1524 x 51 x 1072	KPQAG-4260-NN	1,811	1,876	1,952
	24 x 2 x 54 3/8	610 x 51 x 1386	KPQAG-5424-NN	1,205	1,270	1,346
	30 x 2 x 54 3/8	762 x 51 x 1386	KPQAG-5430-NN	1,306	1,370	1,447
	36 x 2 x 54 3/8	914 x 51 x 1386	KPQAG-5436-NN	1,417	1,482	1,558
	42 x 2 x 54 3/8	1067 x 51 x 1386	KPQAG-5442-NN	1,541	1,605	1,682
	48 x 2 x 54 3/8	1219 x 51 x 1386	KPQAG-5448-NN	1,670	1,735	1,811
	60 x 2 x 54 3/8	1524 x 51 x 1386	KPQAG-5460-NN	1,887	1,952	2,028
	24 x 2 x 66 7/8	610 x 51 x 1700	KPQAG-6624-NN	1,229	1,294	1,370
	30 x 2 x 66 7/8	762 x 51 x 1700	KPQAG-6630-NN	1,335	1,400	1,476
	36 x 2 x 66 7/8	914 x 51 x 1700	KPQAG-6636-NN	1,447	1,511	1,588
	42 x 2 x 66 7/8	1067 x 51 x 1700	KPQAG-6642-NN	1,570	1,635	1,711
	48 x 2 x 66 7/8	1219 x 51 x 1700	KPQAG-6648-NN	1,706	1,770	1,847
	60 x 2 x 66 7/8	1524 x 51 x 1700	KPQAG-6660-NN	1,929	1,994	2,070

A combination of upholsteries may be applied to each side of a panel. If they are of different grades, the cost of the upholstery will be based on the price of the higher grade.

Fabric acoustical panels, 12 3/8" H glass segment, powered

	W x D x H (in)	W x D x H (mm)	Code	Gr1 (\$)	Gr2 (\$)	Gr3 (\$)
<i>Panel includes the tempered glass segment, in-line junction connectors, top trim, 2 covers with cut-outs and knock-out communication plates for the raceway, the electric system and the in-line power connector. To be ordered separately: duplex receptacles KER - - -; refer to pages 29 and 30.</i>						
	24 x 2 x 42 1/4	610 x 51 x 1072	KPQAG-4224-P	1,288	1,353	1,429
	30 x 2 x 42 1/4	762 x 51 x 1072	KPQAG-4230-P	1,411	1,476	1,552
	36 x 2 x 42 1/4	914 x 51 x 1072	KPQAG-4236-P	1,534	1,599	1,676
	42 x 2 x 42 1/4	1067 x 51 x 1072	KPQAG-4242-P	1,652	1,717	1,793
	48 x 2 x 42 1/4	1219 x 51 x 1072	KPQAG-4248-P	1,788	1,852	1,929
	60 x 2 x 42 1/4	1524 x 51 x 1072	KPQAG-4260-P	2,052	2,117	2,193
	24 x 2 x 54 3/8	610 x 51 x 1386	KPQAG-5424-P	1,329	1,393	1,471
	30 x 2 x 54 3/8	762 x 51 x 1386	KPQAG-5430-P	1,458	1,523	1,599
	36 x 2 x 54 3/8	914 x 51 x 1386	KPQAG-5436-P	1,588	1,652	1,729
	42 x 2 x 54 3/8	1067 x 51 x 1386	KPQAG-5442-P	1,711	1,776	1,852
	48 x 2 x 54 3/8	1219 x 51 x 1386	KPQAG-5448-P	1,852	1,917	1,994
	60 x 2 x 54 3/8	1524 x 51 x 1386	KPQAG-5460-P	2,129	2,193	2,270
	24 x 2 x 66 7/8	610 x 51 x 1700	KPQAG-6624-P	1,353	1,417	1,494
	30 x 2 x 66 7/8	762 x 51 x 1700	KPQAG-6630-P	1,487	1,552	1,628
	36 x 2 x 66 7/8	914 x 51 x 1700	KPQAG-6636-P	1,623	1,688	1,764
	42 x 2 x 66 7/8	1067 x 51 x 1700	KPQAG-6642-P	1,746	1,811	1,887
	48 x 2 x 66 7/8	1219 x 51 x 1700	KPQAG-6648-P	1,887	1,952	2,028
	60 x 2 x 66 7/8	1524 x 51 x 1700	KPQAG-6660-P	2,169	2,234	2,311

Specify 3-circuit or 4-circuit system (surcharge of \$130 for 4-circuit). At the end of the product code add, in this order: trim color, upholstery for sides A/B, clear (CG) or frosted (TG) finish for tempered glass (TG, surcharge of \$59).

Laminate panels, 12 3/8" H glass segment, non-powered

	W x D x H (in)	W x D x H (mm)	Code	Gr1 (\$)	Gr2 (\$)	Gr3 (\$)
<i>Panel includes the tempered glass segment, in-line junction connectors, top trim, and 2 covers with no cut-outs for raceway.</i>						
	24 x 2 x 42 1/4	610 x 51 x 1072	KPQLG-4224-NN			1,559
	30 x 2 x 42 1/4	762 x 51 x 1072	KPQLG-4230-NN			1,645
	36 x 2 x 42 1/4	914 x 51 x 1072	KPQLG-4236-NN			1,744
	42 x 2 x 42 1/4	1067 x 51 x 1072	KPQLG-4242-NN			1,934
	48 x 2 x 42 1/4	1219 x 51 x 1072	KPQLG-4248-NN			2,040
	24 x 2 x 54 3/8	610 x 51 x 1386	KPQLG-5424-NN			1,682
	30 x 2 x 54 3/8	762 x 51 x 1386	KPQLG-5430-NN			1,768
	36 x 2 x 54 3/8	914 x 51 x 1386	KPQLG-5436-NN			1,867
	42 x 2 x 54 3/8	1067 x 51 x 1386	KPQLG-5442-NN			2,119
	48 x 2 x 54 3/8	1219 x 51 x 1386	KPQLG-5448-NN			2,224

A combination of upholsteries may be applied to each side of a panel. If they are of different grades, the cost of the upholstery will be based on the price of the higher grade.

	W x D x H (in)	W x D x H (mm)	Code	Gr1 (\$)	Gr2 (\$)	Gr3 (\$)
Laminate panels, 12 3/8" H glass segment, non-powered (cont'd)						
	24 x 2 x 66 7/8	610 x 51 x 1700	KPQLG-6624-NN			1,805
	30 x 2 x 66 7/8	762 x 51 x 1700	KPQLG-6630-NN			1,897
	36 x 2 x 66 7/8	914 x 51 x 1700	KPQLG-6636-NN			1,996
	42 x 2 x 66 7/8	1067 x 51 x 1700	KPQLG-6642-NN			2,304
	48 x 2 x 66 7/8	1219 x 51 x 1700	KPQLG-6648-NN			2,409

A combination of HPL finishes may be applied to each side of a panel. At the end of the product code add, in this order: trim color, HPL finishes for sides A/B, clear (CG) or frosted (TG) finish for tempered glass (TG, surcharge of \$59).

	W x D x H (in)	W x D x H (mm)	Code	Gr1 (\$)	Gr2 (\$)	Gr3 (\$)
Laminate panels, 12 3/8" H glass segment, powered						
<i>Panel includes the tempered glass segment, in-line junction connectors, top trim, 2 covers with cut-outs and knock-out communication plates for the raceway, the electric system and the in-line power connector. To be ordered separately: duplex receptacles KER - - -; refer to pages 29 and 30.</i>						
	24 x 2 x 42 1/4	610 x 51 x 1072	KPQLG-4224-P			1,688
	30 x 2 x 42 1/4	762 x 51 x 1072	KPQLG-4230-P			1,811
	36 x 2 x 42 1/4	914 x 51 x 1072	KPQLG-4236-P			1,922
	42 x 2 x 42 1/4	1067 x 51 x 1072	KPQLG-4242-P			2,119
	48 x 2 x 42 1/4	1219 x 51 x 1072	KPQLG-4248-P			2,230
	24 x 2 x 54 3/8	610 x 51 x 1386	KPQLG-5424-P			1,811
	30 x 2 x 54 3/8	762 x 51 x 1386	KPQLG-5430-P			1,934
	36 x 2 x 54 3/8	914 x 51 x 1386	KPQLG-5436-P			2,045
	42 x 2 x 54 3/8	1067 x 51 x 1386	KPQLG-5442-P			2,304
	48 x 2 x 54 3/8	1219 x 51 x 1386	KPQLG-5448-P			2,415
	24 x 2 x 66 7/8	610 x 51 x 1700	KPQLG-6624-P			1,934
	30 x 2 x 66 7/8	762 x 51 x 1700	KPQLG-6630-P			2,064
	36 x 2 x 66 7/8	914 x 51 x 1700	KPQLG-6636-P			2,175
	42 x 2 x 66 7/8	1067 x 51 x 1700	KPQLG-6642-P			2,489
	48 x 2 x 66 7/8	1219 x 51 x 1700	KPQLG-6648-P			2,600

Specify 3-circuit or 4-circuit system (surcharge of \$130 for 4-circuit). At the end of the product code add, in this order: trim color, HPL finishes for sides A/B, clear (CG) or frosted (TG) finish for tempered glass (TG, surcharge of \$59).

	W x D x H (in)	W x D x H (mm)	Code	Gr1 (\$)	Gr2 (\$)	Gr3 (\$)
Laminate/fabric combined panels, 12 3/8" H glass segment, non-powered						
<i>Panel includes the tempered glass segment, in-line junction connectors, top trim, and 2 covers with no cut-outs for raceway.</i>						
	24 x 2 x 42 1/4	610 x 51 x 1072	KPQCG-4224-NN	1,440	1,476	1,518
	30 x 2 x 42 1/4	762 x 51 x 1072	KPQCG-4230-NN	1,534	1,570	1,612
	36 x 2 x 42 1/4	914 x 51 x 1072	KPQCG-4236-NN	1,635	1,670	1,711
	42 x 2 x 42 1/4	1067 x 51 x 1072	KPQCG-4242-NN	1,782	1,817	1,858
	48 x 2 x 42 1/4	1219 x 51 x 1072	KPQCG-4248-NN	1,887	1,923	1,964
	24 x 2 x 54 3/8	610 x 51 x 1386	KPQCG-5424-NN	1,552	1,588	1,628
	30 x 2 x 54 3/8	762 x 51 x 1386	KPQCG-5430-NN	1,646	1,682	1,723
	36 x 2 x 54 3/8	914 x 51 x 1386	KPQCG-5436-NN	1,753	1,788	1,829
	42 x 2 x 54 3/8	1067 x 51 x 1386	KPQCG-5442-NN	1,923	1,958	1,999
	48 x 2 x 54 3/8	1219 x 51 x 1386	KPQCG-5448-NN	2,028	2,064	2,106
	24 x 2 x 66 7/8	610 x 51 x 1700	KPQCG-6624-NN	1,612	1,646	1,688
	30 x 2 x 66 7/8	762 x 51 x 1700	KPQCG-6630-NN	1,706	1,740	1,782
	36 x 2 x 66 7/8	914 x 51 x 1700	KPQCG-6636-NN	1,805	1,840	1,882
	42 x 2 x 66 7/8	1067 x 51 x 1700	KPQCG-6642-NN	1,994	2,028	2,070
	48 x 2 x 66 7/8	1219 x 51 x 1700	KPQCG-6648-NN	2,099	2,135	2,176

At the end of the product code add, in this order: trim color, HPL finish for side A, upholstery for side B, clear (CG) or frosted (TG) finish for tempered glass (TG, surcharge of \$59).

	W x D x H (in)	W x D x H (mm)	Code	Gr1 (\$)	Gr2 (\$)	Gr3 (\$)
Laminate/fabric combined panels, 12 3/8" H, glass segment, powered						
<i>Panel includes the tempered glass segment, in-line junction connectors, top trim, 2 covers with cut-outs and knock-out communication plates for the raceway, the electric system and the in-line power connector. To be ordered separately: duplex receptacles KER - - -; refer to pages 29 and 30.</i>						
	24 x 2 x 42 1/4	610 x 51 x 1072	KPQCG-4224-P	1,565	1,599	1,641
	30 x 2 x 42 1/4	762 x 51 x 1072	KPQCG-4230-P	1,693	1,729	1,770
	36 x 2 x 42 1/4	914 x 51 x 1072	KPQCG-4236-P	1,805	1,840	1,882
	42 x 2 x 42 1/4	1067 x 51 x 1072	KPQCG-4242-P	1,958	1,994	2,035
	48 x 2 x 42 1/4	1219 x 51 x 1072	KPQCG-4248-P	2,070	2,106	2,146
	24 x 2 x 54 3/8	610 x 51 x 1386	KPQCG-5424-P	1,676	1,711	1,753
	30 x 2 x 54 3/8	762 x 51 x 1386	KPQCG-5430-P	1,805	1,840	1,882
	36 x 2 x 54 3/8	914 x 51 x 1386	KPQCG-5436-P	1,923	1,958	1,999
	42 x 2 x 54 3/8	1067 x 51 x 1386	KPQCG-5442-P	2,099	2,135	2,176
	48 x 2 x 54 3/8	1219 x 51 x 1386	KPQCG-5448-P	2,211	2,247	2,287

PARADIGM Panel System

	W x D x H (in)	W x D x H (mm)	Code	Gr1 (\$)	Gr2 (\$)	Gr3 (\$)
Laminate/fabric combined panels, 12 3/8" H glass segment, powered (cont'd)	24 x 2 x 66 7/8	610 x 51 x 1700	KPQCG-6624- P-	1,735	1,770	1,811
	30 x 2 x 66 7/8	762 x 51 x 1700	KPQCG-6630- P-	1,864	1,900	1,941
	36 x 2 x 66 7/8	914 x 51 x 1700	KPQCG-6636- P-	1,976	2,012	2,052
	42 x 2 x 66 7/8	1067 x 51 x 1700	KPQCG-6642- P-	2,169	2,205	2,247
	48 x 2 x 66 7/8	1219 x 51 x 1700	KPQCG-6648- P-	2,281	2,317	2,358

Specify 3-circuit or 4-circuit system (surcharge of \$130 for 4-circuit). At the end of the product code add, in this order: trim color, HPL finish for side A, upholstery for side B, clear (CG) or frosted (TG) finish for tempered glass (TG, surcharge of \$59).

	W x D x H (in)	W x D x H (mm)	Code	Gr1 (\$)	Gr2 (\$)	Gr3 (\$)
Fabric acoustical panels, 24 3/4" H glass segment, non-powered	<i>Panel includes the tempered glass segment, in-line junction connectors, top trim, and 2 covers with no cut-outs for raceway.</i>					
	24 x 2 x 54 3/8	610 x 51 x 1386	KPHAG-5424- NN-	1,235	1,299	1,376
	30 x 2 x 54 3/8	762 x 51 x 1386	KPHAG-5430- NN-	1,335	1,400	1,476
	36 x 2 x 54 3/8	914 x 51 x 1386	KPHAG-5436- NN-	1,447	1,511	1,588
	42 x 2 x 54 3/8	1067 x 51 x 1386	KPHAG-5442- NN-	1,570	1,635	1,711
	48 x 2 x 54 3/8	1219 x 51 x 1386	KPHAG-5448- NN-	1,706	1,770	1,847
	60 x 2 x 54 3/8	1524 x 51 x 1386	KPHAG-5460- NN-	1,934	1,999	2,075
	24 x 2 x 66 7/8	610 x 51 x 1700	KPHAG-6624- NN-	1,276	1,341	1,417
	30 x 2 x 66 7/8	762 x 51 x 1700	KPHAG-6630- NN-	1,388	1,453	1,529
	36 x 2 x 66 7/8	914 x 51 x 1700	KPHAG-6636- NN-	1,505	1,570	1,646
	42 x 2 x 66 7/8	1067 x 51 x 1700	KPHAG-6642- NN-	1,635	1,699	1,776
	48 x 2 x 66 7/8	1219 x 51 x 1700	KPHAG-6648- NN-	1,782	1,847	1,923
	60 x 2 x 66 7/8	1524 x 51 x 1700	KPHAG-6660- NN-	2,012	2,075	2,153

At the end of the product code add, in this order: trim color, upholstery for sides A/B, clear (CG) or frosted (TG) finish for tempered glass (TG, surcharge of \$141).

	W x D x H (in)	W x D x H (mm)	Code	Gr1 (\$)	Gr2 (\$)	Gr3 (\$)
Fabric acoustical panels, 24 3/4" H glass segment, powered	<i>Panel includes the tempered glass segment, in-line junction connectors, top trim, 2 covers with cut-outs and knock-out communication plates for the raceway, the electric system and the in-line power connector. To be ordered separately: duplex receptacles KER - - -; refer to pages 29 and 30.</i>					
	24 x 2 x 54 3/8	610 x 51 x 1386	KPHAG-5424- P-	1,364	1,429	1,505
	30 x 2 x 54 3/8	762 x 51 x 1386	KPHAG-5430- P-	1,494	1,558	1,635
	36 x 2 x 54 3/8	914 x 51 x 1386	KPHAG-5436- P-	1,628	1,693	1,770
	42 x 2 x 54 3/8	1067 x 51 x 1386	KPHAG-5442- P-	1,753	1,817	1,894
	48 x 2 x 54 3/8	1219 x 51 x 1386	KPHAG-5448- P-	1,894	1,958	2,035
	60 x 2 x 54 3/8	1524 x 51 x 1386	KPHAG-5460- P-	2,182	2,247	2,323
	24 x 2 x 66 7/8	610 x 51 x 1700	KPHAG-6624- P-	1,406	1,471	1,547
	30 x 2 x 66 7/8	762 x 51 x 1700	KPHAG-6630- P-	1,547	1,612	1,688
	36 x 2 x 66 7/8	914 x 51 x 1700	KPHAG-6636- P-	1,682	1,746	1,823
	42 x 2 x 66 7/8	1067 x 51 x 1700	KPHAG-6642- P-	1,811	1,876	1,952
	48 x 2 x 66 7/8	1219 x 51 x 1700	KPHAG-6648- P-	1,964	2,028	2,106
	60 x 2 x 66 7/8	1524 x 51 x 1700	KPHAG-6660- P-	2,258	2,323	2,399

Specify 3-circuit or 4-circuit system (surcharge of \$130 for 4-circuit). At the end of the product code add, in this order: trim color, upholstery for sides A/B, clear (CG) or frosted (TG) finish for tempered glass (TG, surcharge of \$141).

	W x D x H (in)	W x D x H (mm)	Code	Gr1 (\$)	Gr2 (\$)	Gr3 (\$)
Laminate panels, 24 3/4" H glass segment, non-powered	<i>Panel includes the tempered glass segment, in-line junction connectors, top trim, and 2 covers with no cut-outs for raceway.</i>					
	24 x 2 x 54 3/8	610 x 51 x 1386	KPHLG-5424- NN-			1,700
	30 x 2 x 54 3/8	762 x 51 x 1386	KPHLG-5430- NN-			1,786
	36 x 2 x 54 3/8	914 x 51 x 1386	KPHLG-5436- NN-			1,892
	42 x 2 x 54 3/8	1067 x 51 x 1386	KPHLG-5442- NN-			2,107
	48 x 2 x 54 3/8	1219 x 51 x 1386	KPHLG-5448- NN-			2,218
	24 x 2 x 66 7/8	610 x 51 x 1700	KPHLG-6624- NN-			1,830
	30 x 2 x 66 7/8	762 x 51 x 1700	KPHLG-6630- NN-			1,922
	36 x 2 x 66 7/8	914 x 51 x 1700	KPHLG-6636- NN-			2,027
	42 x 2 x 66 7/8	1067 x 51 x 1700	KPHLG-6642- NN-			2,304
	48 x 2 x 66 7/8	1219 x 51 x 1700	KPHLG-6648- NN-			2,415

At the end of the product code add, in this order: trim color, HPL finishes for sides A/B, clear (CG) or frosted (TG) finish for tempered glass (TG, surcharge of \$141).

	W x D x H (in)	W x D x H (mm)	Code	Gr1 (\$)	Gr2 (\$)	Gr3 (\$)
Laminate panels, 24 3/4" H glass segment, powered	<i>Panel includes the tempered glass segment, in-line junction connectors, top trim, 2 covers with cut-outs and knock-out communication plates for the raceway, the electric system and the in-line power connector. To be ordered separately: duplex receptacles KER - - -; refer to pages 29 and 30.</i>					
	24 x 2 x 54 3/8	610 x 51 x 1386	KPHLG-5424- P-			1,836
	30 x 2 x 54 3/8	762 x 51 x 1386	KPHLG-5430- P-			1,966
	36 x 2 x 54 3/8	914 x 51 x 1386	KPHLG-5436- P-			2,089
	42 x 2 x 54 3/8	1067 x 51 x 1386	KPHLG-5442- P-			2,298
	48 x 2 x 54 3/8	1219 x 51 x 1386	KPHLG-5448- P-			2,421
	24 x 2 x 66 7/8	610 x 51 x 1700	KPHLG-6624- P-			1,966
	30 x 2 x 66 7/8	762 x 51 x 1700	KPHLG-6630- P-			2,094
	36 x 2 x 66 7/8	914 x 51 x 1700	KPHLG-6636- P-			2,218
	42 x 2 x 66 7/8	1067 x 51 x 1700	KPHLG-6642- P-			2,495
	48 x 2 x 66 7/8	1219 x 51 x 1700	KPHLG-6648- P-			2,619

A combination of HPL finishes may be applied to each side of a panel.

	W x D x H (in)	W x D x H (mm)	Code	Gr1 (\$)	Gr2 (\$)	Gr3 (\$)
Laminate/fabric combined panels, 24 3/4" H glass segment, non-powered	<i>Panel includes the tempered glass segment, in-line junction connectors, top trim, and 2 covers with no cut-outs for raceway.</i>					
	24 x 2 x 54 3/8	610 x 51 x 1386	KPHCG-5424- NN-	1,576	1,612	1,652
	30 x 2 x 54 3/8	762 x 51 x 1386	KPHCG-5430- NN-	1,676	1,711	1,753
	36 x 2 x 54 3/8	914 x 51 x 1386	KPHCG-5436- NN-	1,782	1,817	1,858
	42 x 2 x 54 3/8	1067 x 51 x 1386	KPHCG-5442- NN-	1,952	1,988	2,028
	48 x 2 x 54 3/8	1219 x 51 x 1386	KPHCG-5448- NN-	2,064	2,099	2,140
	24 x 2 x 66 7/8	610 x 51 x 1700	KPHCG-6624- NN-	1,693	1,729	1,770
	30 x 2 x 66 7/8	762 x 51 x 1700	KPHCG-6630- NN-	1,793	1,829	1,870
	36 x 2 x 66 7/8	914 x 51 x 1700	KPHCG-6636- NN-	1,905	1,941	1,981
	42 x 2 x 66 7/8	1067 x 51 x 1700	KPHCG-6642- NN-	2,099	2,135	2,176
	48 x 2 x 66 7/8	1219 x 51 x 1700	KPHCG-6648- NN-	2,211	2,247	2,287

At the end of the product code add, in this order: trim color, HPL finish for side A, upholstery for side B, clear (CG) or frosted (TG) finish for tempered glass (TG, surcharge of \$141).

	W x D x H (in)	W x D x H (mm)	Code	Gr1 (\$)	Gr2 (\$)	Gr3 (\$)
Laminate/fabric combined panels, 24 3/4" H glass segment, powered	<i>Panel includes the tempered glass segment, in-line junction connectors, top trim, 2 covers with cut-outs and knock-out communication plates for the raceway, the electric system and the in-line power connector. To be ordered separately: duplex receptacles KER - - -; refer to pages 29 and 30.</i>					
	24 x 2 x 54 3/8	610 x 51 x 1386	KPHCG-5424- P-	1,706	1,740	1,782
	30 x 2 x 54 3/8	762 x 51 x 1386	KPHCG-5430- P-	1,847	1,882	1,923
	36 x 2 x 54 3/8	914 x 51 x 1386	KPHCG-5436- P-	1,970	2,005	2,046
	42 x 2 x 54 3/8	1067 x 51 x 1386	KPHCG-5442- P-	2,129	2,164	2,205
	48 x 2 x 54 3/8	1219 x 51 x 1386	KPHCG-5448- P-	2,258	2,294	2,334
	24 x 2 x 66 7/8	610 x 51 x 1700	KPHCG-6624- P-	1,829	1,864	1,905
	30 x 2 x 66 7/8	762 x 51 x 1700	KPHCG-6630- P-	1,964	1,999	2,041
	36 x 2 x 66 7/8	914 x 51 x 1700	KPHCG-6636- P-	2,093	2,129	2,169
	42 x 2 x 66 7/8	1067 x 51 x 1700	KPHCG-6642- P-	2,281	2,317	2,358
	48 x 2 x 66 7/8	1219 x 51 x 1700	KPHCG-6648- P-	2,405	2,440	2,482

Specify 3-circuit or 4-circuit system (surcharge of \$130 for 4-circuit). At the end of the product code add, in this order: trim color, HPL finish for side A, upholstery for side B, clear (CG) or frosted (TG) finish for tempered glass (TG, surcharge of \$141).

W x D x H (in)	W x D x H (mm)	Code	Gr1 (\$)	Gr2 (\$)	Gr3 (\$)
----------------	----------------	------	----------	----------	----------

SEGMENTED PANELS – 1 FABRIC UPPER SEGMENT

Fabric acoustical panels, 12 3/8" H fabric segment, non-powered

Panel includes in-line junction connectors, top trim and 2 covers with no cut-outs for raceway.

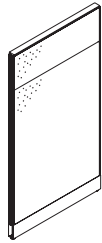

A combination of upholstery may be applied to each side of a panel. If they are of different grades, the cost of the upholstery will be based on the price of the higher grade for the base segment.

24 x 2 x 42 1/4	610 x 51 x 1072	KPQAA-4224-NN-___	964	1,029	1,105
30 x 2 x 42 1/4	762 x 51 x 1072	KPQAA-4230-NN-___	1,058	1,123	1,200
36 x 2 x 42 1/4	914 x 51 x 1072	KPQAA-4236-NN-___	1,165	1,229	1,306
42 x 2 x 42 1/4	1067 x 51 x 1072	KPQAA-4242-NN-___	1,282	1,346	1,424
48 x 2 x 42 1/4	1219 x 51 x 1072	KPQAA-4248-NN-___	1,406	1,471	1,547
60 x 2 x 42 1/4	1524 x 51 x 1072	KPQAA-4260-NN-___	1,617	1,682	1,758
24 x 2 x 54 3/8	610 x 51 x 1386	KPQAA-5424-NN-___	1,006	1,071	1,147
30 x 2 x 54 3/8	762 x 51 x 1386	KPQAA-5430-NN-___	1,105	1,170	1,247
36 x 2 x 54 3/8	914 x 51 x 1386	KPQAA-5436-NN-___	1,217	1,282	1,359
42 x 2 x 54 3/8	1067 x 51 x 1386	KPQAA-5442-NN-___	1,341	1,406	1,482
48 x 2 x 54 3/8	1219 x 51 x 1386	KPQAA-5448-NN-___	1,476	1,541	1,617
60 x 2 x 54 3/8	1524 x 51 x 1386	KPQAA-5460-NN-___	1,693	1,758	1,835
24 x 2 x 66 7/8	610 x 51 x 1700	KPQAA-6624-NN-___	1,035	1,100	1,176
30 x 2 x 66 7/8	762 x 51 x 1700	KPQAA-6630-NN-___	1,135	1,200	1,276
36 x 2 x 66 7/8	914 x 51 x 1700	KPQAA-6636-NN-___	1,252	1,317	1,393
42 x 2 x 66 7/8	1067 x 51 x 1700	KPQAA-6642-NN-___	1,376	1,440	1,518
48 x 2 x 66 7/8	1219 x 51 x 1700	KPQAA-6648-NN-___	1,511	1,576	1,652
60 x 2 x 66 7/8	1524 x 51 x 1700	KPQAA-6660-NN-___	1,735	1,800	1,876

At the end of the product code add, in this order: trim color, upholstery for sides A/B for the base segment, upholstery for sides A/B for the upper segment.

Fabric acoustical panels, 12 3/8" H fabric segment, powered

Panel includes in-line junction connectors, top trim, 2 covers with cut-outs and knock-out communication plates for the raceway, the electric system, and the in-line power connector. To be ordered separately: duplex receptacles KER -_-_-; refer to pages 29 and 30.

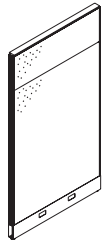

A combination of upholstery may be applied to each side of a panel. If they are of different grades, the cost of the upholstery will be based on the price of the higher grade for the base segment.

24 x 2 x 42 1/4	610 x 51 x 1072	KPQAA-4224- P-___	1,088	1,152	1,229
30 x 2 x 42 1/4	762 x 51 x 1072	KPQAA-4230- P-___	1,212	1,276	1,353
36 x 2 x 42 1/4	914 x 51 x 1072	KPQAA-4236- P-___	1,335	1,400	1,476
42 x 2 x 42 1/4	1067 x 51 x 1072	KPQAA-4242- P-___	1,453	1,518	1,594
48 x 2 x 42 1/4	1219 x 51 x 1072	KPQAA-4248- P-___	1,588	1,652	1,729
60 x 2 x 42 1/4	1524 x 51 x 1072	KPQAA-4260- P-___	1,852	1,917	1,994
24 x 2 x 54 3/8	610 x 51 x 1386	KPQAA-5424- P-___	1,135	1,200	1,276
30 x 2 x 54 3/8	762 x 51 x 1386	KPQAA-5430- P-___	1,264	1,329	1,406
36 x 2 x 54 3/8	914 x 51 x 1386	KPQAA-5436- P-___	1,393	1,458	1,534
42 x 2 x 54 3/8	1067 x 51 x 1386	KPQAA-5442- P-___	1,518	1,581	1,659
48 x 2 x 54 3/8	1219 x 51 x 1386	KPQAA-5448- P-___	1,652	1,717	1,793
60 x 2 x 54 3/8	1524 x 51 x 1386	KPQAA-5460- P-___	1,934	1,999	2,075
24 x 2 x 66 7/8	610 x 51 x 1700	KPQAA-6624- P-___	1,158	1,223	1,299
30 x 2 x 66 7/8	762 x 51 x 1700	KPQAA-6630- P-___	1,288	1,353	1,429
36 x 2 x 66 7/8	914 x 51 x 1700	KPQAA-6636- P-___	1,424	1,487	1,565
42 x 2 x 66 7/8	1067 x 51 x 1700	KPQAA-6642- P-___	1,547	1,612	1,688
48 x 2 x 66 7/8	1219 x 51 x 1700	KPQAA-6648- P-___	1,688	1,753	1,829
60 x 2 x 66 7/8	1524 x 51 x 1700	KPQAA-6660- P-___	1,970	2,035	2,111

Specify 3-circuit or 4-circuit system (surcharge of \$130 for 4-circuit). At the end of the product code add, in this order: trim color, upholstery for sides A/B for the base segment, upholstery for sides A/B for the upper segment.

Laminate panels, 12 3/8" H fabric segment, non-powered

Panel includes in-line junction connectors, top trim, and 2 covers with no cut-outs for the raceway.

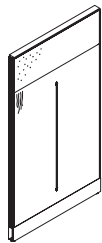

24 x 2 x 42 1/4	610 x 51 x 1072	KPQLA-4224-NN-___			1,355
30 x 2 x 42 1/4	762 x 51 x 1072	KPQLA-4230-NN-___			1,441
36 x 2 x 42 1/4	914 x 51 x 1072	KPQLA-4236-NN-___			1,534
42 x 2 x 42 1/4	1067 x 51 x 1072	KPQLA-4242-NN-___			1,732
48 x 2 x 42 1/4	1219 x 51 x 1072	KPQLA-4248-NN-___			1,830
24 x 2 x 54 3/8	610 x 51 x 1386	KPQLA-5424-NN-___			1,478
30 x 2 x 54 3/8	762 x 51 x 1386	KPQLA-5430-NN-___			1,565
36 x 2 x 54 3/8	914 x 51 x 1386	KPQLA-5436-NN-___			1,658
42 x 2 x 54 3/8	1067 x 51 x 1386	KPQLA-5442-NN-___			1,916
48 x 2 x 54 3/8	1219 x 51 x 1386	KPQLA-5448-NN-___			2,015

W x D x H (in)	W x D x H (mm)	Code	Price (\$)
----------------	----------------	------	------------

Laminate panels, 12 3/8" H fabric segment, non-powered (cont'd)

A combination of HPL finishes and upholstery may be applied to each side of a panel.

At the end of the product code add, in this order: trim color, HPL finishes for sides A/B for the base segment, upholstery for sides A/B for the upper segment.

Laminate panels, 12 3/8" H fabric segment, powered

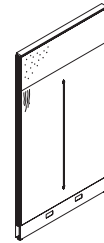

A combination of HPL finishes and upholstery may be applied to each side of a panel.

Panel includes in-line junction connectors, top trim, 2 covers with cut-outs and knock-out communication plates for the raceway, the electric system, and the in-line power connector. To be ordered separately: duplex receptacles KER -_-_-; refer to pages 29 and 30.

24 x 2 x 42 1/4	610 x 51 x 1072	KPQLA-4224- P-___	1,485
30 x 2 x 42 1/4	762 x 51 x 1072	KPQLA-4230- P-___	1,602
36 x 2 x 42 1/4	914 x 51 x 1072	KPQLA-4236- P-___	1,712
42 x 2 x 42 1/4	1067 x 51 x 1072	KPQLA-4242- P-___	1,910
48 x 2 x 42 1/4	1219 x 51 x 1072	KPQLA-4248- P-___	2,020
24 x 2 x 54 3/8	610 x 51 x 1386	KPQLA-5424- P-___	1,608
30 x 2 x 54 3/8	762 x 51 x 1386	KPQLA-5430- P-___	1,725
36 x 2 x 54 3/8	914 x 51 x 1386	KPQLA-5436- P-___	1,836
42 x 2 x 54 3/8	1067 x 51 x 1386	KPQLA-5442- P-___	2,094
48 x 2 x 54 3/8	1219 x 51 x 1386	KPQLA-5448- P-___	2,205
24 x 2 x 66 7/8	610 x 51 x 1700	KPQLA-6624- P-___	1,732
30 x 2 x 66 7/8	762 x 51 x 1700	KPQLA-6630- P-___	1,855
36 x 2 x 66 7/8	914 x 51 x 1700	KPQLA-6636- P-___	1,966
42 x 2 x 66 7/8	1067 x 51 x 1700	KPQLA-6642- P-___	2,279
48 x 2 x 66 7/8	1219 x 51 x 1700	KPQLA-6648- P-___	2,390

Specify 3-circuit or 4-circuit system (surcharge of \$130 for 4-circuit). At the end of the product code add, in this order: trim color, HPL finishes for sides A/B for the base segment, upholstery for sides A/B for the upper segment.

Fabric acoustical panels, 24 3/4" H fabric segment, non-powered

Panel includes in-line junction connectors, top trim, and 2 covers with no cut-outs for the raceway.

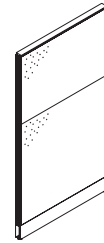

A combination of upholstery may be applied to each side of a panel. If they are of different grades, the cost of the upholstery will be based on the price of the higher grade for the base segment.

W x D x H (in)	W x D x H (mm)	Code	Gr1	Gr2	Gr3
24 x 2 x 54 3/8	610 x 51 x 1386	KPHAA-5424-NN-___	1,000	1,064	1,141
30 x 2 x 54 3/8	762 x 51 x 1386	KPHAA-5430-NN-___	1,100	1,165	1,241
36 x 2 x 54 3/8	914 x 51 x 1386	KPHAA-5436-NN-___	1,212	1,276	1,353
42 x 2 x 54 3/8	1067 x 51 x 1386	KPHAA-5442-NN-___	1,329	1,393	1,471
48 x 2 x 54 3/8	1219 x 51 x 1386	KPHAA-5448-NN-___	1,464	1,529	1,605
60 x 2 x 54 3/8	1524 x 51 x 1386	KPHAA-5460-NN-___	1,676	1,740	1,817
24 x 2 x 66 7/8	610 x 51 x 1700	KPHAA-6624-NN-___	1,040	1,105	1,182
30 x 2 x 66 7/8	762 x 51 x 1700	KPHAA-6630-NN-___	1,152	1,217	1,294
36 x 2 x 66 7/8	914 x 51 x 1700	KPHAA-6636-NN-___	1,264	1,329	1,406
42 x 2 x 66 7/8	1067 x 51 x 1700	KPHAA-6642-NN-___	1,393	1,458	1,534
48 x 2 x 66 7/8	1219 x 51 x 1700	KPHAA-6648-NN-___	1,529	1,594	1,670
60 x 2 x 66 7/8	1524 x 51 x 1700	KPHAA-6660-NN-___	1,753	1,817	1,894

At the end of the product code add, in this order: trim color, upholstery for sides A/B for the base segment, upholstery for sides A/B for the upper segment.

Fabric acoustical panels, 24 3/4" H fabric segment, powered

Panel includes in-line junction connectors, top trim, 2 covers with cut-outs and knock-out communication plates for the raceway, the electric system, and the in-line power connector. To be ordered separately: duplex receptacles KER -_-_-; refer to pages 29 and 30.

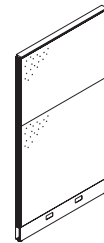

24 x 2 x 54 3/8	610 x 51 x 1386	KPHAA-5424- P-___	1,123	1,188	1,264
30 x 2 x 54 3/8	762 x 51 x 1386	KPHAA-5430- P-___	1,259	1,323	1,400
36 x 2 x 54 3/8	914 x 51 x 1386	KPHAA-5436- P-___	1,382	1,447	1,523
42 x 2 x 54 3/8	1067 x 51 x 1386	KPHAA-5442- P-___	1,505	1,570	1,646
48 x 2 x 54 3/8	1219 x 51 x 1386	KPHAA-5448- P-___	1,641	1,706	1,782
60 x 2 x 54 3/8	1524 x 51 x 1386	KPHAA-5460- P-___	1,917	1,981	2,059
24 x 2 x 66 7/8	610 x 51 x 1700	KPHAA-6624- P-___	1,170	1,235	1,312
30 x 2 x 66 7/8	762 x 51 x 1700	KPHAA-6630- P-___	1,306	1,370	1,447

	W x D x H (in)	W x D x H (mm)	Code	Gr1 (\$)	Gr2 (\$)	Gr3 (\$)
Fabric acoustical panels, 24 3/4" H fabric segment, powered (cont'd)	36 x 2 x 66 7/8	914 x 51 x 1700	KPHAA-6636- P-	1,440	1,505	1,581
	42 x 2 x 66 7/8	1067 x 51 x 1700	KPHAA-6642- P-	1,565	1,628	1,706
	48 x 2 x 66 7/8	1219 x 51 x 1700	KPHAA-6648- P-	1,711	1,776	1,852
	60 x 2 x 66 7/8	1524 x 51 x 1700	KPHAA-6660- P-	1,994	2,059	2,135

A combination of upholsteries may be applied to each side of a panel. If they are of different grades, the cost of the upholstery will be based on the price of the higher grade for the base segment.

Specify 3-circuit or 4-circuit system (surcharge of \$130 for 4-circuit). At the end of the product code add, in this order: trim color, HPL finishes for sides A/B for the base segment, upholstery for sides A/B for the upper segment.

Laminate panels, 24 3/4" H fabric segment, non-powered *Panel includes in-line junction connectors, top trim, 2 covers with no cut-outs for the raceway.*

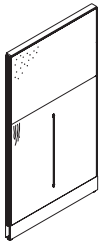

A combination of HPL finishes and upholstery may be applied to each side of a panel.

	W x D x H (in)	W x D x H (mm)	Code	Price (\$)
Laminate panels, 24 3/4" H fabric segment, non-powered	24 x 2 x 54 3/8	610 x 51 x 1386	KPHLA-5424-NN-	1,460
	30 x 2 x 54 3/8	762 x 51 x 1386	KPHLA-5430-NN-	1,559
	36 x 2 x 54 3/8	914 x 51 x 1386	KPHLA-5436-NN-	1,663
	42 x 2 x 54 3/8	1067 x 51 x 1386	KPHLA-5442-NN-	1,867
	48 x 2 x 54 3/8	1219 x 51 x 1386	KPHLA-5448-NN-	1,984
	24 x 2 x 66 7/8	610 x 51 x 1700	KPHLA-6624-NN-	1,589
	30 x 2 x 66 7/8	762 x 51 x 1700	KPHLA-6630-NN-	1,688
	36 x 2 x 66 7/8	914 x 51 x 1700	KPHLA-6636-NN-	1,793
	42 x 2 x 66 7/8	1067 x 51 x 1700	KPHLA-6642-NN-	2,064
	48 x 2 x 66 7/8	1219 x 51 x 1700	KPHLA-6648-NN-	2,181

At the end of the product code add, in this order: trim color, HPL finishes for sides A/B for the base segment, upholstery for sides A/B for the upper segment.

Laminate panels, 24 3/4" H fabric segment, powered *Panel includes in-line junction connectors, top trim, 2 covers with cut-outs and knock-out communication plates for the raceway, the electric system, and the in-line power connector. To be ordered separately: duplex receptacles KER - - - -; refer to pages 29 and 30.*

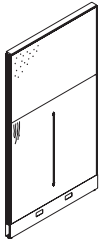

A combination of HPL finishes and upholstery may be applied to each side of a panel.

	W x D x H (in)	W x D x H (mm)	Code	Price (\$)
Laminate panels, 24 3/4" H fabric segment, powered	24 x 2 x 54 3/8	610 x 51 x 1386	KPHLA-5424- P-	1,596
	30 x 2 x 54 3/8	762 x 51 x 1386	KPHLA-5430- P-	1,732
	36 x 2 x 54 3/8	914 x 51 x 1386	KPHLA-5436- P-	1,848
	42 x 2 x 54 3/8	1067 x 51 x 1386	KPHLA-5442- P-	2,064
	48 x 2 x 54 3/8	1219 x 51 x 1386	KPHLA-5448- P-	2,181
	24 x 2 x 66 7/8	610 x 51 x 1700	KPHLA-6624- P-	1,725
	30 x 2 x 66 7/8	762 x 51 x 1700	KPHLA-6630- P-	1,860
	36 x 2 x 66 7/8	914 x 51 x 1700	KPHLA-6636- P-	1,978
	42 x 2 x 66 7/8	1067 x 51 x 1700	KPHLA-6642- P-	2,255
	48 x 2 x 66 7/8	1219 x 51 x 1700	KPHLA-6648- P-	2,372

Specify 3-circuit or 4-circuit system (surcharge of \$130 for 4-circuit). At the end of the product code add, in this order: trim color, HPL finishes for sides A/B for the base segment, upholstery for sides A/B for the upper segment.

SEGMENTED PANELS – 1 LAMINATE UPPER SEGMENT

Laminate panels, 12 3/8" H laminate segment, non-powered *Panel includes in-line junction connectors, top trim, and 2 covers with no cut-outs for the raceway.*

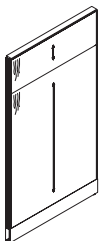

	W x D x H (in)	W x D x H (mm)	Code	Price (\$)
Laminate panels, 12 3/8" H laminate segment, non-powered	24 x 2 x 42 1/4	610 x 51 x 1072	KPQLL-4224-NN-	1,515
	30 x 2 x 42 1/4	762 x 51 x 1072	KPQLL-4230-NN-	1,596
	36 x 2 x 42 1/4	914 x 51 x 1072	KPQLL-4236-NN-	1,676
	42 x 2 x 42 1/4	1067 x 51 x 1072	KPQLL-4242-NN-	1,978
	48 x 2 x 42 1/4	1219 x 51 x 1072	KPQLL-4248-NN-	2,052
	24 x 2 x 54 3/8	610 x 51 x 1386	KPQLL-5424-NN-	1,688
	30 x 2 x 54 3/8	762 x 51 x 1386	KPQLL-5430-NN-	1,774
	36 x 2 x 54 3/8	914 x 51 x 1386	KPQLL-5436-NN-	1,855
	42 x 2 x 54 3/8	1067 x 51 x 1386	KPQLL-5442-NN-	2,237
	48 x 2 x 54 3/8	1219 x 51 x 1386	KPQLL-5448-NN-	2,311

	W x D x H (in)	W x D x H (mm)	Code	Price (\$)
Laminate panels, 12 3/8" H laminate segment, non-powered (cont'd)	24 x 2 x 66 7/8	610 x 51 x 1700	KPQLL-6624-NN-	1,860
	30 x 2 x 66 7/8	762 x 51 x 1700	KPQLL-6630-NN-	1,947
	36 x 2 x 66 7/8	914 x 51 x 1700	KPQLL-6636-NN-	2,033
	42 x 2 x 66 7/8	1067 x 51 x 1700	KPQLL-6642-NN-	2,483
	48 x 2 x 66 7/8	1219 x 51 x 1700	KPQLL-6648-NN-	2,569

A combination of HPL finishes may be applied to each side of a panel.

At the end of the product code add, in this order: trim color, HPL finishes for sides A/B for the base segment, HPL finishes for sides A/B for the upper segment.

Laminate panels, 12 3/8" H laminate segment, powered *Panel includes in-line junction connectors, top trim, 2 covers with cut-outs and knock-out communication plates for the raceway, the electric system, and the in-line power connector. To be ordered separately: duplex receptacles KER - - - -; refer to pages 29 and 30.*

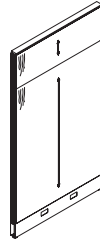

A combination of HPL finishes may be applied to each side of a panel.

	W x D x H (in)	W x D x H (mm)	Code	Price (\$)
Laminate panels, 12 3/8" H laminate segment, powered	24 x 2 x 42 1/4	610 x 51 x 1072	KPQLL-4224- P-	1,700
	30 x 2 x 42 1/4	762 x 51 x 1072	KPQLL-4230- P-	1,818
	36 x 2 x 42 1/4	914 x 51 x 1072	KPQLL-4236- P-	1,922
	42 x 2 x 42 1/4	1067 x 51 x 1072	KPQLL-4242- P-	2,224
	48 x 2 x 42 1/4	1219 x 51 x 1072	KPQLL-4248- P-	2,323
	24 x 2 x 54 3/8	610 x 51 x 1386	KPQLL-5424- P-	1,873
	30 x 2 x 54 3/8	762 x 51 x 1386	KPQLL-5430- P-	2,003
	36 x 2 x 54 3/8	914 x 51 x 1386	KPQLL-5436- P-	2,107
	42 x 2 x 54 3/8	1067 x 51 x 1386	KPQLL-5442- P-	2,483
	48 x 2 x 54 3/8	1219 x 51 x 1386	KPQLL-5448- P-	2,582
	24 x 2 x 66 7/8	610 x 51 x 1700	KPQLL-6624- P-	2,045
	30 x 2 x 66 7/8	762 x 51 x 1700	KPQLL-6630- P-	2,175
36 x 2 x 66 7/8	914 x 51 x 1700	KPQLL-6636- P-	2,286	
42 x 2 x 66 7/8	1067 x 51 x 1700	KPQLL-6642- P-	2,735	
48 x 2 x 66 7/8	1219 x 51 x 1700	KPQLL-6648- P-	2,840	

Specify 3-circuit or 4-circuit system (surcharge of \$130 for 4-circuit). At the end of the product code add, in this order: trim color, HPL finishes for sides A/B for the base segment, HPL finishes for sides A/B for the upper segment.

Laminate panels, 24 3/4" H laminate segment, non-powered *Panel includes in-line junction connectors, top trim, and 2 covers with no cut-outs for the raceway.*

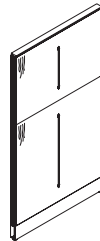

A combination of HPL finishes may be applied to each side of a panel.

	W x D x H (in)	W x D x H (mm)	Code	Price (\$)
Laminate panels, 24 3/4" H laminate segment, non-powered	24 x 2 x 54 3/8	610 x 51 x 1386	KPHLL-5424-NN-	1,712
	30 x 2 x 54 3/8	762 x 51 x 1386	KPHLL-5430-NN-	1,805
	36 x 2 x 54 3/8	914 x 51 x 1386	KPHLL-5436-NN-	1,879
	42 x 2 x 54 3/8	1067 x 51 x 1386	KPHLL-5442-NN-	2,267
	48 x 2 x 54 3/8	1219 x 51 x 1386	KPHLL-5448-NN-	2,348
	24 x 2 x 66 7/8	610 x 51 x 1700	KPHLL-6624-NN-	1,897
	30 x 2 x 66 7/8	762 x 51 x 1700	KPHLL-6630-NN-	1,978
	36 x 2 x 66 7/8	914 x 51 x 1700	KPHLL-6636-NN-	2,064
	42 x 2 x 66 7/8	1067 x 51 x 1700	KPHLL-6642-NN-	2,520
	48 x 2 x 66 7/8	1219 x 51 x 1700	KPHLL-6648-NN-	2,606

At the end of the product code add, in this order: trim color, HPL finishes for sides A/B for the base segment, HPL finishes for sides A/B for the upper segment.

Laminate panels, 24 3/4" H laminate segment, powered *Panel includes in-line junction connectors, top trim, 2 covers with cut-outs and knock-out communication plates for the raceway, the electric system, and the in-line power connector. To be ordered separately: duplex receptacles KER - - - -; refer to pages 29 and 30.*

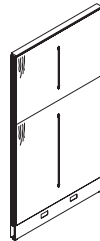

A combination of HPL finishes may be applied to each side of a panel.

	W x D x H (in)	W x D x H (mm)	Code	Price (\$)
Laminate panels, 24 3/4" H laminate segment, powered	24 x 2 x 54 3/8	610 x 51 x 1386	KPHLL-5424- P-	1,897
	30 x 2 x 54 3/8	762 x 51 x 1386	KPHLL-5430- P-	2,027
	36 x 2 x 54 3/8	914 x 51 x 1386	KPHLL-5436- P-	2,131
	42 x 2 x 54 3/8	1067 x 51 x 1386	KPHLL-5442- P-	2,520
	48 x 2 x 54 3/8	1219 x 51 x 1386	KPHLL-5448- P-	2,619
	24 x 2 x 66 7/8	610 x 51 x 1700	KPHLL-6624- P-	2,082
	30 x 2 x 66 7/8	762 x 51 x 1700	KPHLL-6630- P-	2,205
	36 x 2 x 66 7/8	914 x 51 x 1700	KPHLL-6636- P-	2,316
	42 x 2 x 66 7/8	1067 x 51 x 1700	KPHLL-6642- P-	2,772
	48 x 2 x 66 7/8	1219 x 51 x 1700	KPHLL-6648- P-	2,877

Specify 3-circuit or 4-circuit system (surcharge of \$130 for 4-circuit). At the end of the product code add, in this order: trim color, HPL finishes for sides A/B for the base segment, HPL finishes for sides A/B for the upper segment.

SEGMENTED PANELS – FABRIC AND GLASS UPPER SEGMENTS			Gr1	Gr2	Gr3
W x D x H (in)	W x D x H (mm)	Code	(\$)	(\$)	(\$)
Fabric acoustical panels, 12 3/8" H fabric segment, 12 3/8" H glass segment, non-powered					
<i>Panel includes the tempered glass segment, in-line junction connectors, top trim, and 2 covers with no cut-outs for raceway.</i>					
24 x 2 x 54 5/8	610 x 51 x 1386	KPQAAG-5424-NN-	1,588	1,652	1,729
30 x 2 x 54 5/8	762 x 51 x 1386	KPQAAG-5430-NN-	1,723	1,788	1,864
36 x 2 x 54 5/8	914 x 51 x 1386	KPQAAG-5436-NN-	1,882	1,947	2,023
42 x 2 x 54 5/8	1067 x 51 x 1386	KPQAAG-5442-NN-	2,046	2,111	2,187
48 x 2 x 54 5/8	1219 x 51 x 1386	KPQAAG-5448-NN-	2,229	2,294	2,370
60 x 2 x 54 5/8	1524 x 51 x 1386	KPQAAG-5460-NN-	2,529	2,593	2,670
24 x 2 x 66 7/8	610 x 51 x 1700	KPQAAG-6624-NN-	1,635	1,699	1,776
30 x 2 x 66 7/8	762 x 51 x 1700	KPQAAG-6630-NN-	1,776	1,840	1,917
36 x 2 x 66 7/8	914 x 51 x 1700	KPQAAG-6636-NN-	1,934	1,999	2,075
42 x 2 x 66 7/8	1067 x 51 x 1700	KPQAAG-6642-NN-	2,111	2,176	2,252
48 x 2 x 66 7/8	1219 x 51 x 1700	KPQAAG-6648-NN-	2,299	2,364	2,440
60 x 2 x 66 7/8	1524 x 51 x 1700	KPQAAG-6660-NN-	2,605	2,670	2,746

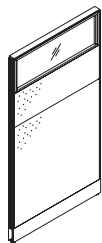

A combination of upholstery may be applied to each side of a panel. If they are of different grades, the cost of the upholstery will be based on the price of the higher grade for the base segment.

Fabric acoustical panels, 12 3/8" H fabric segment, 12 3/8" H glass segment, powered					
<i>Panel includes the tempered glass segment, in-line junction connectors, top trim, 2 covers with cut-outs and knock-out communication plates for the raceway, the electric system and the in-line power connector. To be ordered separately: duplex receptacles KER - - - -; refer to pages 29 and 30.</i>					
24 x 2 x 54 5/8	610 x 51 x 1386	KPQAAG-5424- P-	1,717	1,782	1,858
30 x 2 x 54 5/8	762 x 51 x 1386	KPQAAG-5430- P-	1,882	1,947	2,023
36 x 2 x 54 5/8	914 x 51 x 1386	KPQAAG-5436- P-	2,052	2,117	2,193
42 x 2 x 54 5/8	1067 x 51 x 1386	KPQAAG-5442- P-	2,216	2,281	2,358
48 x 2 x 54 5/8	1219 x 51 x 1386	KPQAAG-5448- P-	2,411	2,475	2,552
60 x 2 x 54 5/8	1524 x 51 x 1386	KPQAAG-5460- P-	2,770	2,835	2,911
24 x 2 x 66 7/8	610 x 51 x 1700	KPQAAG-6624- P-	1,758	1,823	1,900
30 x 2 x 66 7/8	762 x 51 x 1700	KPQAAG-6630- P-	1,929	1,994	2,070
36 x 2 x 66 7/8	914 x 51 x 1700	KPQAAG-6636- P-	2,106	2,169	2,247
42 x 2 x 66 7/8	1067 x 51 x 1700	KPQAAG-6642- P-	2,281	2,346	2,423
48 x 2 x 66 7/8	1219 x 51 x 1700	KPQAAG-6648- P-	2,475	2,540	2,616
60 x 2 x 66 7/8	1524 x 51 x 1700	KPQAAG-6660- P-	2,846	2,911	2,987

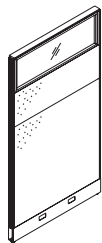

A combination of upholstery may be applied to each side of a panel. If they are of different grades, the cost of the upholstery will be based on the price of the higher grade for the base segment.

Laminate panels, 12 3/8" H fabric segment, 12 3/8" H glass segment, non-powered					
<i>Panel includes the tempered glass segment, in-line junction connectors, top trim, and 2 covers with no cut-outs for the raceway.</i>					
24 x 2 x 54 5/8	610 x 51 x 1386	KPQLAG-5424-NN-	\$ 2,008		
30 x 2 x 54 5/8	762 x 51 x 1386	KPQLAG-5430-NN-	2,138		
36 x 2 x 54 5/8	914 x 51 x 1386	KPQLAG-5436-NN-	2,286		
42 x 2 x 54 5/8	1067 x 51 x 1386	KPQLAG-5442-NN-	2,532		
48 x 2 x 54 5/8	1219 x 51 x 1386	KPQLAG-5448-NN-	2,692		
24 x 2 x 66 7/8	610 x 51 x 1700	KPQLAG-6624-NN-	2,131		
30 x 2 x 66 7/8	762 x 51 x 1700	KPQLAG-6630-NN-	2,261		
36 x 2 x 66 7/8	914 x 51 x 1700	KPQLAG-6636-NN-	2,409		
42 x 2 x 66 7/8	1067 x 51 x 1700	KPQLAG-6642-NN-	2,717		
48 x 2 x 66 7/8	1219 x 51 x 1700	KPQLAG-6648-NN-	2,877		

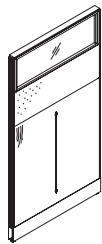

A combination of HPL finishes and upholstery may be applied to each side of a panel.

Laminate panels, 12 3/8" H fabric segment, 12 3/8" H glass segment, powered			Gr1	Gr2	Gr3
W x D x H (in)	W x D x H (mm)	Code	(\$)	(\$)	(\$)
<i>Panel includes the tempered glass segment, in-line junction connectors, top trim, 2 covers with cut-outs and knock-out communication plates for the raceway, the electric system and the in-line power connector. To be ordered separately: duplex receptacles KER - - - -; refer to pages 29 and 30.</i>					
24 x 2 x 54 5/8	610 x 51 x 1386	KPQLAG-5424- P-	2,138		
30 x 2 x 54 5/8	762 x 51 x 1386	KPQLAG-5430- P-	2,304		
36 x 2 x 54 5/8	914 x 51 x 1386	KPQLAG-5436- P-	2,464		
42 x 2 x 54 5/8	1067 x 51 x 1386	KPQLAG-5442- P-	2,717		
48 x 2 x 54 5/8	1219 x 51 x 1386	KPQLAG-5448- P-	2,883		
24 x 2 x 66 7/8	610 x 51 x 1700	KPQLAG-6624- P-	2,261		
30 x 2 x 66 7/8	762 x 51 x 1700	KPQLAG-6630- P-	2,427		
36 x 2 x 66 7/8	914 x 51 x 1700	KPQLAG-6636- P-	2,587		
42 x 2 x 66 7/8	1067 x 51 x 1700	KPQLAG-6642- P-	2,902		
48 x 2 x 66 7/8	1219 x 51 x 1700	KPQLAG-6648- P-	3,068		

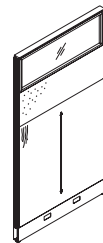

A combination of HPL finishes and upholstery may be applied to each side of a panel.

SEGMENTED PANELS – 2 FABRIC UPPER SEGMENTS			Gr1	Gr2	Gr3
W x D x H (in)	W x D x H (mm)	Code	(\$)	(\$)	(\$)
Fabric acoustical panels, 2 fabric segments 12 3/8" H, non-powered					
<i>Panel includes in-line junction connectors, top trim, and 2 covers with no cut-outs for the raceway.</i>					
24 x 2 x 54 5/8	610 x 51 x 1386	KPQAAA-5424-NN-	1,393	1,458	1,534
30 x 2 x 54 5/8	762 x 51 x 1386	KPQAAA-5430-NN-	1,523	1,588	1,664
36 x 2 x 54 5/8	914 x 51 x 1386	KPQAAA-5436-NN-	1,682	1,746	1,823
42 x 2 x 54 5/8	1067 x 51 x 1386	KPQAAA-5442-NN-	1,847	1,911	1,988
48 x 2 x 54 5/8	1219 x 51 x 1386	KPQAAA-5448-NN-	2,035	2,099	2,176
60 x 2 x 54 5/8	1524 x 51 x 1386	KPQAAA-5460-NN-	2,334	2,399	2,475
24 x 2 x 66 7/8	610 x 51 x 1700	KPQAAA-6624-NN-	1,435	1,500	1,576
30 x 2 x 66 7/8	762 x 51 x 1700	KPQAAA-6630-NN-	1,576	1,641	1,717
36 x 2 x 66 7/8	914 x 51 x 1700	KPQAAA-6636-NN-	1,735	1,800	1,876
42 x 2 x 66 7/8	1067 x 51 x 1700	KPQAAA-6642-NN-	1,911	1,976	2,052
48 x 2 x 66 7/8	1219 x 51 x 1700	KPQAAA-6648-NN-	2,099	2,164	2,240
60 x 2 x 66 7/8	1524 x 51 x 1700	KPQAAA-6660-NN-	2,411	2,475	2,552

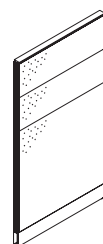

A combination of upholstery may be applied to each side of a panel. If they are of different grades, the cost of the upholstery will be based on the price of the higher grade for the base segment.

Fabric acoustical panels, 2 fabric segments 12 3/8" H, powered					
<i>Panel includes in-line junction connectors, top trim, 2 covers with cut-outs for the raceway, the electric system, and the in-line power connector. To be ordered separately: duplex receptacles KER - - - -; refer to pages 29 and 30.</i>					
24 x 2 x 54 5/8	610 x 51 x 1386	KPQAAA-5424- P-	1,518	1,581	1,659
30 x 2 x 54 5/8	762 x 51 x 1386	KPQAAA-5430- P-	1,682	1,746	1,823
36 x 2 x 54 5/8	914 x 51 x 1386	KPQAAA-5436- P-	1,852	1,917	1,994
42 x 2 x 54 5/8	1067 x 51 x 1386	KPQAAA-5442- P-	2,023	2,088	2,164
48 x 2 x 54 5/8	1219 x 51 x 1386	KPQAAA-5448- P-	2,211	2,276	2,352
60 x 2 x 54 5/8	1524 x 51 x 1386	KPQAAA-5460- P-	2,569	2,634	2,710
24 x 2 x 66 7/8	610 x 51 x 1700	KPQAAA-6624- P-	1,558	1,623	1,699
30 x 2 x 66 7/8	762 x 51 x 1700	KPQAAA-6630- P-	1,729	1,793	1,870
36 x 2 x 66 7/8	914 x 51 x 1700	KPQAAA-6636- P-	1,911	1,976	2,052
42 x 2 x 66 7/8	1067 x 51 x 1700	KPQAAA-6642- P-	2,082	2,146	2,223
48 x 2 x 66 7/8	1219 x 51 x 1700	KPQAAA-6648- P-	2,281	2,346	2,423
60 x 2 x 66 7/8	1524 x 51 x 1700	KPQAAA-6660- P-	2,652	2,717	2,793

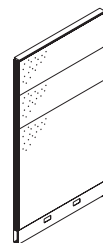

A combination of upholstery may be applied to each side of a panel. If they are of different grades, the cost of the upholstery will be based on the price of the higher grade for the base segment.

Specify 3-circuit or 4-circuit system (surcharge of \$130 for 4-circuit). At the end of the product code add, in this order: trim color, HPL finishes for sides A/B of the base segment, upholstery for sides A/B of the middle segment, clear (CG) or frosted (TG) finish for tempered glass (TG, surcharge of \$59).

At the end of the product code add, in this order: trim color, upholstery for sides A/B for the base segment, upholstery for sides A/B for the middle segment, upholstery for sides A/B for the upper segment.

Specify 3-circuit or 4-circuit system (surcharge of \$130 for 4-circuit). At the end of the product code add, in this order: trim color, upholstery for sides A/B of the base segment, upholstery for sides A/B of the middle segment, upholstery for sides A/B of the upper segment.

W x D x H (in)	W x D x H (mm)	Code	Price (\$)
Laminate panels, 2 fabric segments 12³/₈" H, non-powered			
<i>Panel includes in-line junction connectors, top trim, and 2 covers with no cut-outs for the raceway.</i>			
24 x 2 x 54 ³ / ₈	610 x 51 x 1386	KPQLAA-5424-NN-___	1,805
30 x 2 x 54 ³ / ₈	762 x 51 x 1386	KPQLAA-5430-NN-___	1,929
36 x 2 x 54 ³ / ₈	914 x 51 x 1386	KPQLAA-5436-NN-___	2,076
42 x 2 x 54 ³ / ₈	1067 x 51 x 1386	KPQLAA-5442-NN-___	2,328
48 x 2 x 54 ³ / ₈	1219 x 51 x 1386	KPQLAA-5448-NN-___	2,489
24 x 2 x 66 ⁷ / ₈	610 x 51 x 1700	KPQLAA-6624-NN-___	1,929
30 x 2 x 66 ⁷ / ₈	762 x 51 x 1700	KPQLAA-6630-NN-___	2,052
36 x 2 x 66 ⁷ / ₈	914 x 51 x 1700	KPQLAA-6636-NN-___	2,200
42 x 2 x 66 ⁷ / ₈	1067 x 51 x 1700	KPQLAA-6642-NN-___	2,513
48 x 2 x 66 ⁷ / ₈	1219 x 51 x 1700	KPQLAA-6648-NN-___	2,673

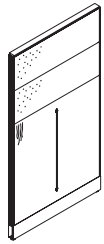

A combination of HPL finishes and upholstery may be applied to each side of a panel.

W x D x H (in)	W x D x H (mm)	Code	Price (\$)
Laminate panels, 2 fabric segments 12³/₈" H, powered			
<i>Panel includes in-line junction connectors, top trim, 2 covers with cut-outs for the raceway, the electric system, and the in-line power connector. To be ordered separately: duplex receptacles KER - - - ; refer to pages 29 and 30.</i>			
24 x 2 x 54 ³ / ₈	610 x 51 x 1386	KPQLAA-5424- P-___	1,934
30 x 2 x 54 ³ / ₈	762 x 51 x 1386	KPQLAA-5430- P-___	2,094
36 x 2 x 54 ³ / ₈	914 x 51 x 1386	KPQLAA-5436- P-___	2,255
42 x 2 x 54 ³ / ₈	1067 x 51 x 1386	KPQLAA-5442- P-___	2,508
48 x 2 x 54 ³ / ₈	1219 x 51 x 1386	KPQLAA-5448- P-___	2,673
24 x 2 x 66 ⁷ / ₈	610 x 51 x 1700	KPQLAA-6624- P-___	2,057
30 x 2 x 66 ⁷ / ₈	762 x 51 x 1700	KPQLAA-6630- P-___	2,218
36 x 2 x 66 ⁷ / ₈	914 x 51 x 1700	KPQLAA-6636- P-___	2,378
42 x 2 x 66 ⁷ / ₈	1067 x 51 x 1700	KPQLAA-6642- P-___	2,692
48 x 2 x 66 ⁷ / ₈	1219 x 51 x 1700	KPQLAA-6648- P-___	2,858

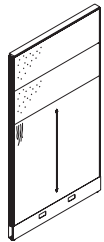

A combination of HPL finishes and upholstery may be applied to each side of a panel.

At the end of the product code add, in this order: trim color, HPL finishes for sides A/B for the base segment, upholstery for sides A/B for the middle segment, upholstery for sides A/B for the upper segment.

Specify 3-circuit or 4-circuit system (surcharge of \$130 for 4-circuit). At the end of the product code add, in this order: trim color, HPL finishes for sides A/B of the base segment, upholstery for sides A/B of the middle segment, upholstery for sides A/B of the upper segment.

LAMINATE GALLERY PANELS

Laminate gallery panels, end-of-run, single
Is installed at the end of a monolithic or segmented panel and serves as a return panel. Corner braces included to fasten to the front of a surface. Note: An end-of-run trim of variable height KVETS-__ is required if the monolithic or segmented panel is taller than the end panel; refer to page 28.

22 x 1 x 29 ⁷ / ₈	559 x 25 x 758	KPLES-3022-NN- -	488
26 x 1 x 29 ⁷ / ₈	660 x 25 x 758	KPLES-3026-NN- -	506
32 x 1 x 29 ⁷ / ₈	813 x 25 x 758	KPLES-3032-NN- -	523
38 x 1 x 29 ⁷ / ₈	965 x 25 x 758	KPLES-3038-NN- -	535
50 x 1 x 29 ⁷ / ₈	1270 x 25 x 758	KPLES-3050-NN- -	553
62 x 1 x 29 ⁷ / ₈	1575 x 25 x 758	KPLES-3062-NN- -	582
22 x 1 x 42 ¹ / ₄	559 x 25 x 1072	KPLES-4222-NN- -	523
26 x 1 x 42 ¹ / ₄	660 x 25 x 1072	KPLES-4226-NN- -	547
32 x 1 x 42 ¹ / ₄	813 x 25 x 1072	KPLES-4232-NN- -	564
38 x 1 x 42 ¹ / ₄	965 x 25 x 1072	KPLES-4238-NN- -	582
50 x 1 x 42 ¹ / ₄	1270 x 25 x 1072	KPLES-4250-NN- -	606
62 x 1 x 42 ¹ / ₄	1575 x 25 x 1072	KPLES-4262-NN- -	647
22 x 1 x 48 ³ / ₈	559 x 25 x 1229	KPLES-4822-NN- -	541
26 x 1 x 48 ³ / ₈	660 x 25 x 1229	KPLES-4826-NN- -	564
32 x 1 x 48 ³ / ₈	813 x 25 x 1229	KPLES-4832-NN- -	588
38 x 1 x 48 ³ / ₈	965 x 25 x 1229	KPLES-4838-NN- -	612
50 x 1 x 48 ³ / ₈	1270 x 25 x 1229	KPLES-4850-NN- -	635
62 x 1 x 48 ³ / ₈	1575 x 25 x 1229	KPLES-4862-NN- -	676
22 x 1 x 54 ³ / ₈	559 x 25 x 1386	KPLES-5422-NN- -	559
26 x 1 x 54 ³ / ₈	660 x 25 x 1386	KPLES-5426-NN- -	582
32 x 1 x 54 ³ / ₈	813 x 25 x 1386	KPLES-5432-NN- -	606
38 x 1 x 54 ³ / ₈	965 x 25 x 1386	KPLES-5438-NN- -	635
50 x 1 x 54 ³ / ₈	1270 x 25 x 1386	KPLES-5450-NN- -	659
62 x 1 x 54 ³ / ₈	1575 x 25 x 1386	KPLES-5462-NN- -	711

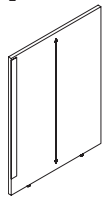
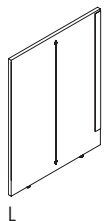

Contrary to the pictograms above, panels over 50" (1270 mm) W have a horizontal wood grain rather than a vertical one.

Specify if a left-side (L) or right-side (R) installation. At the end of the product code add, in this order: trim color, laminate finish.

Laminate gallery panels with 6¹/₈" H glass, end-of-run, single
Is installed at the end of a monolithic or segmented panel and serves as a return panel. Panel includes tempered glass screen and corner braces to fasten to the front of a surface. Note: An end-of-run trim of variable height KVETS-__ is required if the monolithic or segmented panel is taller than the end panel; refer to page 28.

<i>29⁷/₈" (758 mm) H panel with 6¹/₈" (157 mm) H glass.</i>			
22 x 1 x 36	559 x 25 x 915	KPLESG-3022-06- -	765
26 x 1 x 36	660 x 25 x 915	KPLESG-3026-06- -	776
32 x 1 x 36	813 x 25 x 915	KPLESG-3032-06- -	794
38 x 1 x 36	965 x 25 x 915	KPLESG-3038-06- -	823
50 x 1 x 36	1270 x 25 x 915	KPLESG-3050-06- -	859
62 x 1 x 36	1575 x 25 x 915	KPLESG-3062-06- -	917
<i>42¹/₄" (1072 mm) H panel with 6¹/₈" (157 mm) H glass.</i>			
22 x 1 x 48 ³ / ₈	559 x 25 x 1229	KPLESG-4222-06- -	794
26 x 1 x 48 ³ / ₈	660 x 25 x 1229	KPLESG-4226-06- -	812
32 x 1 x 48 ³ / ₈	813 x 25 x 1229	KPLESG-4232-06- -	836
38 x 1 x 48 ³ / ₈	965 x 25 x 1229	KPLESG-4238-06- -	865
50 x 1 x 48 ³ / ₈	1270 x 25 x 1229	KPLESG-4250-06- -	906
62 x 1 x 48 ³ / ₈	1575 x 25 x 1229	KPLESG-4262-06- -	970
<i>48³/₈" (1229 mm) H panel with 6¹/₈" (157 mm) H glass.</i>			
22 x 1 x 54 ³ / ₈	559 x 25 x 1386	KPLESG-4822-06- -	812
26 x 1 x 54 ³ / ₈	660 x 25 x 1386	KPLESG-4826-06- -	836
32 x 1 x 54 ³ / ₈	813 x 25 x 1386	KPLESG-4832-06- -	859
38 x 1 x 54 ³ / ₈	965 x 25 x 1386	KPLESG-4838-06- -	894
50 x 1 x 54 ³ / ₈	1270 x 25 x 1386	KPLESG-4850-06- -	941
62 x 1 x 54 ³ / ₈	1575 x 25 x 1386	KPLESG-4862-06- -	1,011

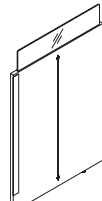
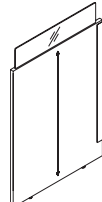

Contrary to the pictograms above, panels over 50" (1270 mm) W have a horizontal wood grain rather than a vertical one.

Laminate gallery panels with 12³/₈" H glass, end-of-run, single
Is installed at the end of a monolithic or segmented panel and serves as a return panel. Panel includes tempered glass screen and corner braces to fasten to the front of a surface. Note: An end-of-run trim of variable height KVETS-__ is required if the monolithic or segmented panel is taller than the end panel; refer to page 28.

<i>29⁷/₈" (758 mm) H panel with 12³/₈" (314 mm) H glass.</i>			
22 x 1 x 42 ¹ / ₄	559 x 25 x 1072	KPLESG-3022-12- -	818
26 x 1 x 42 ¹ / ₄	660 x 25 x 1072	KPLESG-3026-12- -	841
32 x 1 x 42 ¹ / ₄	813 x 25 x 1072	KPLESG-3032-12- -	883
38 x 1 x 42 ¹ / ₄	965 x 25 x 1072	KPLESG-3038-12- -	923
50 x 1 x 42 ¹ / ₄	1270 x 25 x 1072	KPLESG-3050-12- -	982
62 x 1 x 42 ¹ / ₄	1575 x 25 x 1072	KPLESG-3062-12- -	1,064
<i>42¹/₄" (1072 mm) H panel with 12³/₈" (314 mm) H glass.</i>			
22 x 1 x 54 ³ / ₈	559 x 25 x 1386	KPLESG-4222-12- -	847
26 x 1 x 54 ³ / ₈	660 x 25 x 1386	KPLESG-4226-12- -	876
32 x 1 x 54 ³ / ₈	813 x 25 x 1386	KPLESG-4232-12- -	923
38 x 1 x 54 ³ / ₈	965 x 25 x 1386	KPLESG-4238-12- -	970
50 x 1 x 54 ³ / ₈	1270 x 25 x 1386	KPLESG-4250-12- -	1,035
62 x 1 x 54 ³ / ₈	1575 x 25 x 1386	KPLESG-4262-12- -	1,123

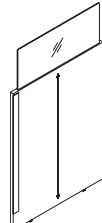
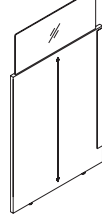

Contrary to the pictograms above, panels over 50" (1270 mm) W have a horizontal wood grain rather than a vertical one.

Specify if a left-side (L) or right-side (R) installation. At the end of the product code add, in this order: trim color, laminate finish, clear (CG) or frosted (TG) finish for tempered glass (TG, surcharge of \$100).

	W x D x H (in)	W x D x H (mm)	Code	Price (\$)
Laminate gallery panels, end-of-run, shared				
<i>Is installed at the end of a monolithic or segmented panel and serves as a return panels. Corner braces included to fasten to the front of a surface. Note: An end-of-run trim of variable height KVETS-__ is required if the monolithic or segmented panel is taller than the end panel; refer to page 28.</i>				
	42 x 1 x 29 ⁷ / ₈	1067 x 25 x 758	KPLED-3042-NN-__	641
	50 x 1 x 29 ⁷ / ₈	1270 x 25 x 758	KPLED-3050-NN-__	676
	62 x 1 x 29 ⁷ / ₈	1575 x 25 x 758	KPLED-3062-NN-__	706
	74 x 1 x 29 ⁷ / ₈	1879 x 25 x 758	KPLED-3074-NN-__	735
	98 x 1 x 29 ⁷ / ₈	2489 x 25 x 758	KPLED-3098-NN-__	771
	42 x 1 x 42 ¹ / ₄	1067 x 25 x 1072	KPLED-4242-NN-__	653
	50 x 1 x 42 ¹ / ₄	1270 x 25 x 1072	KPLED-4250-NN-__	694
	62 x 1 x 42 ¹ / ₄	1575 x 25 x 1072	KPLED-4262-NN-__	729
	74 x 1 x 42 ¹ / ₄	1879 x 25 x 1072	KPLED-4274-NN-__	765
	98 x 1 x 42 ¹ / ₄	2489 x 25 x 1072	KPLED-4298-NN-__	805
	42 x 1 x 48 ³ / ₈	1067 x 25 x 1229	KPLED-4842-NN-__	664
	50 x 1 x 48 ³ / ₈	1270 x 25 x 1229	KPLED-4850-NN-__	711
	62 x 1 x 48 ³ / ₈	1575 x 25 x 1229	KPLED-4862-NN-__	753
	74 x 1 x 48 ³ / ₈	1879 x 25 x 1229	KPLED-4874-NN-__	794
	98 x 1 x 48 ³ / ₈	2489 x 25 x 1229	KPLED-4898-NN-__	841
	42 x 1 x 54 ⁵ / ₈	1067 x 25 x 1386	KPLED-5442-NN-__	676
	50 x 1 x 54 ⁵ / ₈	1270 x 25 x 1386	KPLED-5450-NN-__	729
	62 x 1 x 54 ⁵ / ₈	1575 x 25 x 1386	KPLED-5462-NN-__	776
	74 x 1 x 54 ⁵ / ₈	1879 x 25 x 1386	KPLED-5474-NN-__	823
	98 x 1 x 54 ⁵ / ₈	2489 x 25 x 1386	KPLED-5498-NN-__	876
At the end of the product code add, in this order: trim color, laminate finish.				

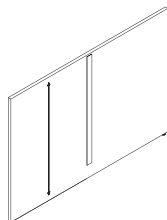

Contrary to the pictogram above, panels over 50" (1270 mm) W have a horizontal wood grain rather than a vertical one.

	W x D x H (in)	W x D x H (mm)	Code	Price (\$)
Laminate gallery panels with 6¹/₈" H glass, end-of-run, shared				
<i>Is installed at the end of a monolithic or segmented panel and serves as a return panels. Panel includes tempered glass screens and corner braces to fasten to the front of a surface. Note: An end-of-run trim of variable height KVETS-__ is required if the monolithic or segmented panel is taller than the end panel; refer to page 28.</i>				
<i>29⁷/₈" (758 mm) H panel with 6¹/₈" (157 mm) H glass.</i>				
	42 x 1 x 36	1067 x 25 x 915	KPLEDG-3042-06-__	917
	50 x 1 x 36	1270 x 25 x 915	KPLEDG-3050-06-__	970
	62 x 1 x 36	1575 x 25 x 915	KPLEDG-3062-06-__	1,035
	74 x 1 x 36	1879 x 25 x 915	KPLEDG-3074-06-__	1,111
	98 x 1 x 36	2489 x 25 x 915	KPLEDG-3098-06-__	1,217
<i>42¹/₄" (1072 mm) H panel with 6¹/₈" (157 mm) H glass.</i>				
	42 x 1 x 48 ³ / ₈	1067 x 25 x 1229	KPLEDG-4242-06-__	941
	50 x 1 x 48 ³ / ₈	1270 x 25 x 1229	KPLEDG-4250-06-__	1,011
	62 x 1 x 48 ³ / ₈	1575 x 25 x 1229	KPLEDG-4262-06-__	1,094
	74 x 1 x 48 ³ / ₈	1879 x 25 x 1229	KPLEDG-4274-06-__	1,188
	98 x 1 x 48 ³ / ₈	2489 x 25 x 1229	KPLEDG-4298-06-__	1,312
<i>48³/₈" (1229 mm) H panel with 6¹/₈" (157 mm) H glass.</i>				
	42 x 1 x 54 ⁵ / ₈	1067 x 25 x 1386	KPLEDG-4842-06-__	964
	50 x 1 x 54 ⁵ / ₈	1270 x 25 x 1386	KPLEDG-4850-06-__	1,040
	62 x 1 x 54 ⁵ / ₈	1575 x 25 x 1386	KPLEDG-4862-06-__	1,129
	74 x 1 x 54 ⁵ / ₈	1879 x 25 x 1386	KPLEDG-4874-06-__	1,229
	98 x 1 x 54 ⁵ / ₈	2489 x 25 x 1386	KPLEDG-4898-06-__	1,359
At the end of the product code add, in this order: trim color, laminate finish, clear (CG) or frosted (TG) finish for tempered glass (TG, surcharge of \$59).				

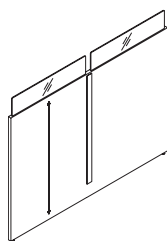

Contrary to the pictogram above, panels over 50" (1270 mm) W have a horizontal wood grain rather than a vertical one.

	W x D x H (in)	W x D x H (mm)	Code	Price (\$)
Laminate gallery panels with 12³/₈" H glass, end-of-run, shared				
<i>Is installed at the end of a monolithic or segmented panel and serves as a return panels. Panel includes tempered glass screens and corner braces to fasten to the front of a surface. Note: An end-of-run trim of variable height KVETS-__ is required if the monolithic or segmented panel is taller than the end panel; refer to page 28.</i>				
<i>29⁷/₈" (758 mm) H panel with 12³/₈" (314 mm) H glass.</i>				
	42 x 1 x 42 ¹ / ₄	1067 x 25 x 1072	KPLEDG-3042-12-__	959
	50 x 1 x 42 ¹ / ₄	1270 x 25 x 1072	KPLEDG-3050-12-__	1,017
	62 x 1 x 42 ¹ / ₄	1575 x 25 x 1072	KPLEDG-3062-12-__	1,111
	74 x 1 x 42 ¹ / ₄	1879 x 25 x 1072	KPLEDG-3074-12-__	1,205
	98 x 1 x 42 ¹ / ₄	2489 x 25 x 1072	KPLEDG-3098-12-__	1,335
<i>42¹/₄" (1072 mm) H panel with 12³/₈" (314 mm) H glass.</i>				
	42 x 1 x 54 ⁵ / ₈	1067 x 25 x 1386	KPLEDG-4242-12-__	982
	50 x 1 x 54 ⁵ / ₈	1270 x 25 x 1386	KPLEDG-4250-12-__	1,058

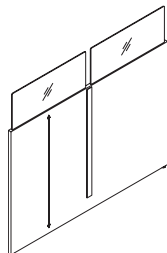

	W x D x H (in)	W x D x H (mm)	Code	Price (\$)
Laminate gallery panels with 12³/₈" H glass, end-of-run, shared (cont'd)				
	62 x 1 x 54 ⁵ / ₈	1575 x 25 x 1386	KPLEDG-4262-12-__	1,170
	74 x 1 x 54 ⁵ / ₈	1879 x 25 x 1386	KPLEDG-4274-12-__	1,282
	98 x 1 x 54 ⁵ / ₈	2489 x 25 x 1386	KPLEDG-4298-12-__	1,429

Contrary to the preceding pictogram, panels over 50" (1270 mm) W have a horizontal wood grain rather than a vertical one.

	W x D x H (in)	W x D x H (mm)	Code	Price (\$)
Laminate gallery panels, intersection, single				
<i>Is installed between two monolithic or segmented panels and serves as a return panel. Corner braces included to fasten to the front of a surface. Note: Two end-of-run trims of variable height KVETS-__ are required if the monolithic or segmented panels are taller than the intersection panel; refer to page 28.</i>				

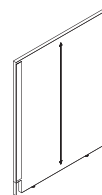

Contrary to the pictogram above, panels over 50" (1270 mm) W have a horizontal wood grain rather than a vertical one.

	22 x 1 x 29 ⁷ / ₈	559 x 25 x 758	KPLMS-3022-NN-__	624
	26 x 1 x 29 ⁷ / ₈	660 x 25 x 758	KPLMS-3026-NN-__	641
	32 x 1 x 29 ⁷ / ₈	813 x 25 x 758	KPLMS-3032-NN-__	659
	38 x 1 x 29 ⁷ / ₈	965 x 25 x 758	KPLMS-3038-NN-__	676
	50 x 1 x 29 ⁷ / ₈	1270 x 25 x 758	KPLMS-3050-NN-__	694
	62 x 1 x 29 ⁷ / ₈	1575 x 25 x 758	KPLMS-3062-NN-__	711
	22 x 1 x 42 ¹ / ₄	559 x 25 x 1072	KPLMS-4222-NN-__	664
	26 x 1 x 42 ¹ / ₄	660 x 25 x 1072	KPLMS-4226-NN-__	688
	32 x 1 x 42 ¹ / ₄	813 x 25 x 1072	KPLMS-4232-NN-__	718
	38 x 1 x 42 ¹ / ₄	965 x 25 x 1072	KPLMS-4238-NN-__	741
	50 x 1 x 42 ¹ / ₄	1270 x 25 x 1072	KPLMS-4250-NN-__	765
	62 x 1 x 42 ¹ / ₄	1575 x 25 x 1072	KPLMS-4262-NN-__	788
	22 x 1 x 48 ³ / ₈	559 x 25 x 1229	KPLMS-4822-NN-__	688
	26 x 1 x 48 ³ / ₈	660 x 25 x 1229	KPLMS-4826-NN-__	718
	32 x 1 x 48 ³ / ₈	813 x 25 x 1229	KPLMS-4832-NN-__	741
	38 x 1 x 48 ³ / ₈	965 x 25 x 1229	KPLMS-4838-NN-__	771
	50 x 1 x 48 ³ / ₈	1270 x 25 x 1229	KPLMS-4850-NN-__	800
	62 x 1 x 48 ³ / ₈	1575 x 25 x 1229	KPLMS-4862-NN-__	829
	22 x 1 x 54 ⁵ / ₈	559 x 25 x 1386	KPLMS-5422-NN-__	711
	26 x 1 x 54 ⁵ / ₈	660 x 25 x 1386	KPLMS-5426-NN-__	741
	32 x 1 x 54 ⁵ / ₈	813 x 25 x 1386	KPLMS-5432-NN-__	771
	38 x 1 x 54 ⁵ / ₈	965 x 25 x 1386	KPLMS-5438-NN-__	805
	50 x 1 x 54 ⁵ / ₈	1270 x 25 x 1386	KPLMS-5450-NN-__	836
	62 x 1 x 54 ⁵ / ₈	1575 x 25 x 1386	KPLMS-5462-NN-__	865

At the end of the product code add, in this order: trim color, laminate finish.

	W x D x H (in)	W x D x H (mm)	Code	Price (\$)
Laminate gallery panels with 6¹/₈" H glass, intersection, single				
<i>Is installed between two monolithic or segmented panels and serves as a return panel. Panel includes tempered glass screen and corner braces to fasten to the front of a surface. Note: Two end-of-run trims of variable height KVETS-__ are required if the monolithic or segmented panels are taller than the intersection panel; refer to page 28.</i>				

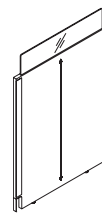

Contrary to the pictogram above, panels over 50" (1270 mm) W have a horizontal wood grain rather than a vertical one.

<i>29⁷/₈" (758 mm) H panel with 6¹/₈" (157 mm) H glass.</i>				
	22 x 1 x 36	559 x 25 x 915	KPLMSG-3022-06-__	883
	26 x 1 x 36	660 x 25 x 915	KPLMSG-3026-06-__	899
	32 x 1 x 36	813 x 25 x 915	KPLMSG-3032-06-__	917
	38 x 1 x 36	965 x 25 x 915	KPLMSG-3038-06-__	946
	50 x 1 x 36	1270 x 25 x 915	KPLMSG-3050-06-__	993
	62 x 1 x 36	1575 x 25 x 915	KPLMSG-3062-06-__	1,035
<i>42¹/₄" (1072 mm) H panel with 6¹/₈" (157 mm) H glass.</i>				
	22 x 1 x 48 ³ / ₈	559 x 25 x 1229	KPLMSG-4222-06-__	923
	26 x 1 x 48 ³ / ₈	660 x 25 x 1229	KPLMSG-4226-06-__	946
	32 x 1 x 48 ³ / ₈	813 x 25 x 1229	KPLMSG-4232-06-__	977
	38 x 1 x 48 ³ / ₈	965 x 25 x 1229	KPLMSG-4238-06-__	1,011
	50 x 1 x 48 ³ / ₈	1270 x 25 x 1229	KPLMSG-4250-06-__	1,064
	62 x 1 x 48 ³ / ₈	1575 x 25 x 1229	KPLMSG-4262-06-__	1,111
<i>48³/₈" (1229 mm) H panel with 6¹/₈" (157 mm) H glass.</i>				
	22 x 1 x 54 ⁵ / ₈	559 x 25 x 1386	KPLMSG-4822-06-__	946
	26 x 1 x 54 ⁵ / ₈	660 x 25 x 1386	KPLMSG-4826-06-__	977
	32 x 1 x 54 ⁵ / ₈	813 x 25 x 1386	KPLMSG-4832-06-__	1,006
	38 x 1 x 54 ⁵ / ₈	965 x 25 x 1386	KPLMSG-4838-06-__	1,047
	50 x 1 x 54 ⁵ / ₈	1270 x 25 x 1386	KPLMSG-4850-06-__	1,100
	62 x 1 x 54 ⁵ / ₈	1575 x 25 x 1386	KPLMSG-4862-06-__	1,147

At the end of the product code add, in this order: trim color, laminate finish, clear (CG) or frosted (TG) finish for tempered glass (TG, surcharge of \$59).

W x D x H (in)	W x D x H (mm)	Code	Price (\$)
Laminate gallery panels with 12 3/8" H glass, intersection, single			
<i>Is installed between two monolithic or segmented panels and serves as a return panel. Panel includes tempered glass screen and corner braces to fasten to the front of a surface. Note: Two end-of-run trims of variable height KVETS-__ are required if the monolithic or segmented panels are taller than the intersection panel; refer to page 28.</i>			
<i>29 7/8" (758 mm) H panel with 12 3/8" (314 mm) H glass.</i>			
22 x 1 x 42 1/4	559 x 25 x 1072	KPLMSG-3022-12-__	899
26 x 1 x 42 1/4	660 x 25 x 1072	KPLMSG-3026-12-__	923
32 x 1 x 42 1/4	813 x 25 x 1072	KPLMSG-3032-12-__	959
38 x 1 x 42 1/4	965 x 25 x 1072	KPLMSG-3038-12-__	993
50 x 1 x 42 1/4	1270 x 25 x 1072	KPLMSG-3050-12-__	1,053
62 x 1 x 42 1/4	1575 x 25 x 1072	KPLMSG-3062-12-__	1,105
<i>42 1/4" (1072 mm) H panel with 12 3/8" (314 mm) H glass.</i>			
22 x 1 x 54 3/8	559 x 25 x 1386	KPLMSG-4222-12-__	946
26 x 1 x 54 3/8	660 x 25 x 1386	KPLMSG-4226-12-__	970
32 x 1 x 54 3/8	813 x 25 x 1386	KPLMSG-4232-12-__	1,017
38 x 1 x 54 3/8	965 x 25 x 1386	KPLMSG-4238-12-__	1,058
50 x 1 x 54 3/8	1270 x 25 x 1386	KPLMSG-4250-12-__	1,123
62 x 1 x 54 3/8	1575 x 25 x 1386	KPLMSG-4262-12-__	1,182
At the end of the product code add, in this order: trim color, laminate finish, clear (CG) or frosted (TG) finish for tempered glass (TG, surcharge of \$100).			

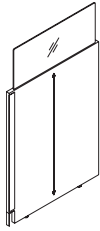

Contrary to the pictogram above, panels over 50" (1270 mm) W have a horizontal wood grain rather than a vertical one.

W x D x H (in)	W x D x H (mm)	Code	Price (\$)
Laminate gallery panels, intersection, shared			
<i>Is installed between two monolithic or segmented panels and serves as a return panel. Panel includes corner braces to fasten to the front of a surface. Note: Two end-of-run trims of variable height KVETS-__ are required if the monolithic or segmented panels are taller than the intersection panel; refer to page 28.</i>			
<i>42 x 1 x 29 7/8" (1067 x 25 x 758 mm) H panel with 12 3/8" (314 mm) H glass.</i>			
42 x 1 x 29 7/8	1067 x 25 x 758	KPLMD-3042-NN-__	822
50 x 1 x 29 7/8	1270 x 25 x 758	KPLMD-3050-NN-__	747
62 x 1 x 29 7/8	1575 x 25 x 758	KPLMD-3062-NN-__	805
74 x 1 x 29 7/8	1879 x 25 x 758	KPLMD-3074-NN-__	870
98 x 1 x 29 7/8	2489 x 25 x 758	KPLMD-3098-NN-__	935
<i>42 x 1 x 42 1/4" (1067 x 25 x 1072 mm) H panel with 12 3/8" (314 mm) H glass.</i>			
42 x 1 x 42 1/4	1067 x 25 x 1072	KPLMD-4242-NN-__	747
50 x 1 x 42 1/4	1270 x 25 x 1072	KPLMD-4250-NN-__	818
62 x 1 x 42 1/4	1575 x 25 x 1072	KPLMD-4262-NN-__	894
74 x 1 x 42 1/4	1879 x 25 x 1072	KPLMD-4274-NN-__	964
98 x 1 x 42 1/4	2489 x 25 x 1072	KPLMD-4298-NN-__	1,035
<i>42 x 1 x 48 3/8" (1067 x 25 x 1229 mm) H panel with 12 3/8" (314 mm) H glass.</i>			
42 x 1 x 48 3/8	1067 x 25 x 1229	KPLMD-4842-NN-__	776
50 x 1 x 48 3/8	1270 x 25 x 1229	KPLMD-4850-NN-__	852
62 x 1 x 48 3/8	1575 x 25 x 1229	KPLMD-4862-NN-__	935
74 x 1 x 48 3/8	1879 x 25 x 1229	KPLMD-4874-NN-__	1,011
98 x 1 x 48 3/8	2489 x 25 x 1229	KPLMD-4898-NN-__	1,088
<i>42 x 1 x 54 3/8" (1067 x 25 x 1386 mm) H panel with 12 3/8" (314 mm) H glass.</i>			
42 x 1 x 54 3/8	1067 x 25 x 1386	KPLMD-5442-NN-__	805
50 x 1 x 54 3/8	1270 x 25 x 1386	KPLMD-5450-NN-__	888
62 x 1 x 54 3/8	1575 x 25 x 1386	KPLMD-5462-NN-__	977
74 x 1 x 54 3/8	1879 x 25 x 1386	KPLMD-5474-NN-__	1,058
98 x 1 x 54 3/8	2489 x 25 x 1386	KPLMD-5498-NN-__	1,141
At the end of the product code add, in this order: trim color, laminate finish.			

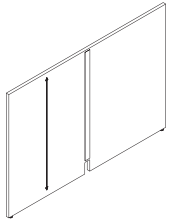

Contrary to the pictogram above, panels over 50" (1270 mm) W have a horizontal wood grain rather than a vertical one.

W x D x H (in)	W x D x H (mm)	Code	Price (\$)
Laminate gallery panels with 6 1/8" H glass, intersection, shared			
<i>Is installed between two monolithic or segmented panels and serves as a return panel. Panel includes tempered glass screens and corner braces to fasten to the front of a surface. Note: Two end-of-run trims of variable height KVETS-__ are required if the monolithic or segmented panels are taller than the intersection panel; refer to page 28.</i>			
<i>29 7/8" (758 mm) H panel with 6 1/8" (157 mm) H glass.</i>			
42 x 1 x 36	1067 x 25 x 915	KPLMDG-3042-06-__	1,040
50 x 1 x 36	1270 x 25 x 915	KPLMDG-3050-06-__	1,105
62 x 1 x 36	1575 x 25 x 915	KPLMDG-3062-06-__	1,170
74 x 1 x 36	1879 x 25 x 915	KPLMDG-3074-06-__	1,259
98 x 1 x 36	2489 x 25 x 915	KPLMDG-3098-06-__	1,370
<i>42 1/4" (1072 mm) H panel with 6 1/8" (157 mm) H glass.</i>			
42 x 1 x 48 3/8	1067 x 25 x 1229	KPLMDG-4242-06-__	1,105
50 x 1 x 48 3/8	1270 x 25 x 1229	KPLMDG-4250-06-__	1,176
62 x 1 x 48 3/8	1575 x 25 x 1229	KPLMDG-4262-06-__	1,252
74 x 1 x 48 3/8	1879 x 25 x 1229	KPLMDG-4274-06-__	1,353
98 x 1 x 48 3/8	2489 x 25 x 1229	KPLMDG-4298-06-__	1,476

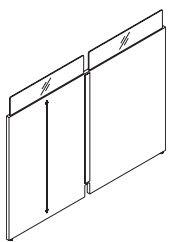

W x D x H (in)	W x D x H (mm)	Code	Price (\$)
Laminate gallery panels with 6 1/8" H glass, intersection, shared (cont'd)			
<i>48 3/8" (1229 mm) H panel with 6 1/8" (157 mm) H glass.</i>			
42 x 1 x 54 3/8	1067 x 25 x 1386	KPLMDG-4842-06-__	1,135
50 x 1 x 54 3/8	1270 x 25 x 1386	KPLMDG-4850-06-__	1,212
62 x 1 x 54 3/8	1575 x 25 x 1386	KPLMDG-4862-06-__	1,299
74 x 1 x 54 3/8	1879 x 25 x 1386	KPLMDG-4874-06-__	1,400
98 x 1 x 54 3/8	2489 x 25 x 1386	KPLMDG-4898-06-__	1,529
Contrary to the preceding pictogram, panels over 50" (1270 mm) W have a horizontal wood grain rather than a vertical one.			

W x D x H (in)	W x D x H (mm)	Code	Price (\$)
Laminate gallery panels with 12 3/8" H glass, intersection, shared			
<i>Is installed between two monolithic or segmented panels and serves as a return panel. Panel includes tempered glass screens and corner braces to fasten to the front of a surface. Note: Two end-of-run trims of variable height KVETS-__ are required if the monolithic or segmented panels are taller than the intersection panel; refer to page 28.</i>			
<i>29 7/8" (758 mm) H panel with 12 3/8" (314 mm) H glass.</i>			
42 x 1 x 42 1/4	1067 x 25 x 1072	KPLMDG-3042-12-__	1,088
50 x 1 x 42 1/4	1270 x 25 x 1072	KPLMDG-3050-12-__	1,152
62 x 1 x 42 1/4	1575 x 25 x 1072	KPLMDG-3062-12-__	1,252
74 x 1 x 42 1/4	1879 x 25 x 1072	KPLMDG-3074-12-__	1,346
98 x 1 x 42 1/4	2489 x 25 x 1072	KPLMDG-3098-12-__	1,487
<i>42 1/4" (1072 mm) H panel with 12 3/8" (314 mm) H glass.</i>			
42 x 1 x 54 3/8	1067 x 25 x 1386	KPLMDG-4242-12-__	1,147
50 x 1 x 54 3/8	1270 x 25 x 1386	KPLMDG-4250-12-__	1,223
62 x 1 x 54 3/8	1575 x 25 x 1386	KPLMDG-4262-12-__	1,335
74 x 1 x 54 3/8	1879 x 25 x 1386	KPLMDG-4274-12-__	1,440
98 x 1 x 54 3/8	2489 x 25 x 1386	KPLMDG-4298-12-__	1,594
At the end of the product code add, in this order: trim color, laminate finish, clear (CG) or frosted (TG) finish for tempered glass (TG, surcharge of \$100).			

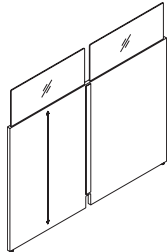

Contrary to the pictogram above, panels over 50" (1270 mm) W have a horizontal wood grain rather than a vertical one.

SCREENS AND STACKABLE PANELS

W x D x H (in)	W x D x H (mm)	Code	Price (\$)
Privacy screens for panels			
<i>Privacy screen includes tempered glass screen and top trim. Is installed on top of a monolithic or segmented panel or of a stackable panel of equal width.</i>			
<i>6 1/8" (157 mm) H.</i>			
23 1/8 x 2 x 6 1/8	593 x 51 x 157	KPFG-0624-__	288
29 1/8 x 2 x 6 1/8	745 x 51 x 157	KPFG-0630-__	306
35 1/8 x 2 x 6 1/8	897 x 51 x 157	KPFG-0636-__	335
41 1/8 x 2 x 6 1/8	1050 x 51 x 157	KPFG-0642-__	365
47 1/8 x 2 x 6 1/8	1202 x 51 x 157	KPFG-0648-__	394
53 1/8 x 2 x 6 1/8	1354 x 51 x 157	KPFG-0654-__	423
<i>12 3/8" (314 mm) H.</i>			
23 1/8 x 2 x 12 3/8	593 x 51 x 314	KPFG-1224-__	318
29 1/8 x 2 x 12 3/8	745 x 51 x 314	KPFG-1230-__	353
35 1/8 x 2 x 12 3/8	897 x 51 x 314	KPFG-1236-__	389
41 1/8 x 2 x 12 3/8	1050 x 51 x 314	KPFG-1242-__	429
47 1/8 x 2 x 12 3/8	1202 x 51 x 314	KPFG-1248-__	465
53 1/8 x 2 x 12 3/8	1354 x 51 x 314	KPFG-1254-__	500
At the end of the product code add, in this order: trim color, clear (CG) or frosted (TG) finish for tempered glass (TG, surcharge of \$59 for 6 1/8" H screen and surcharge of \$100 for 12 3/8" H screen).			

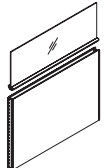

W x D x H (in)	W x D x H (mm)	Code	Price (\$)
Glass stackable panels			
<i>Stackable panel includes tempered glass segment, in-line junction connectors and side rails. Is installed on top of a monolithic or segmented panel or of a stackable panel of equal width.</i>			
<i>12 3/8" (314 mm) H.</i>			
24 x 2 x 12 3/8	610 x 51 x 314	KPSG-1224-__	624
30 x 2 x 12 3/8	762 x 51 x 314	KPSG-1230-__	664
36 x 2 x 12 3/8	914 x 51 x 314	KPSG-1236-__	718
42 x 2 x 12 3/8	1067 x 51 x 314	KPSG-1242-__	765
48 x 2 x 12 3/8	1219 x 51 x 314	KPSG-1248-__	823
60 x 2 x 12 3/8	1524 x 51 x 314	KPSG-1260-__	912
<i>24 3/4" (628 mm) H.</i>			
24 x 2 x 24 3/4	610 x 51 x 628	KPSG-2424-__	664
30 x 2 x 24 3/4	762 x 51 x 628	KPSG-2430-__	706



	W x D x H (in)	W x D x H (mm)	Code	Price (\$)
Glass stackable panels (cont'd)	36 x 2 x 24 ³ / ₄	914 x 51 x 628	KPSG-2436-___	758
	42 x 2 x 24 ³ / ₄	1067 x 51 x 628	KPSG-2442-___	818
	48 x 2 x 24 ³ / ₄	1219 x 51 x 628	KPSG-2448-___	876
	60 x 2 x 24 ³ / ₄	1524 x 51 x 628	KPSG-2460-___	977

At the end of the product code add, in this order: trim color, clear (CG) or frosted (TG) finish for tempered glass (TG, surcharge of \$59 for 12³/₈" H panel and surcharge of \$141 for 24³/₄" H panel).

Fabric acoustical stackable panels

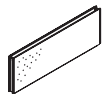

A combination of upholsteries may be applied to each side of a stackable panel. If they are of different grades, the cost of the upholstery will be based on the price of the higher grade.

Stackable panel includes in-line junction connectors and side rails. Is installed on top of a monolithic or segmented panel or of a stackable panel of equal width.

		Gr1	Gr2	Gr3
<i>12³/₈" (314 mm) H.</i>				
24 x 2 x 12 ³ / ₈	610 x 51 x 314	KPSA-1224-___	429	476 523
30 x 2 x 12 ³ / ₈	762 x 51 x 314	KPSA-1230-___	470	517 564
36 x 2 x 12 ³ / ₈	914 x 51 x 314	KPSA-1236-___	517	564 612
42 x 2 x 12 ³ / ₈	1067 x 51 x 314	KPSA-1242-___	570	617 664
48 x 2 x 12 ³ / ₈	1219 x 51 x 314	KPSA-1248-___	624	671 718
60 x 2 x 12 ³ / ₈	1524 x 51 x 314	KPSA-1260-___	718	765 812
<i>24³/₄" (628 mm) H.</i>				
24 x 2 x 24 ³ / ₄	610 x 51 x 628	KPSA-2424-___	465	512 559
30 x 2 x 24 ³ / ₄	762 x 51 x 628	KPSA-2430-___	512	559 606
36 x 2 x 24 ³ / ₄	914 x 51 x 628	KPSA-2436-___	564	612 659
42 x 2 x 24 ³ / ₄	1067 x 51 x 628	KPSA-2442-___	617	664 711
48 x 2 x 24 ³ / ₄	1219 x 51 x 628	KPSA-2448-___	682	729 776
60 x 2 x 24 ³ / ₄	1524 x 51 x 628	KPSA-2460-___	776	823 870

At the end of the product code add, in this order: trim color, upholstery for sides A/B.

Laminate stackable panels

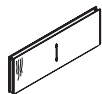

A combination of HPL finishes may be applied to each side of a module.

Stackable panel includes in-line junction connectors and side rails. Is installed on top of a monolithic or segmented panel or of a stackable panel of equal width.

				\$
<i>12³/₈" (314 mm) H.</i>				
24 x 2 x 12 ³ / ₈	610 x 51 x 314	KPSL-1224-___		788
30 x 2 x 12 ³ / ₈	762 x 51 x 314	KPSL-1230-___		808
36 x 2 x 12 ³ / ₈	914 x 51 x 314	KPSL-1236-___		832
42 x 2 x 12 ³ / ₈	1067 x 51 x 314	KPSL-1242-___		894
48 x 2 x 12 ³ / ₈	1219 x 51 x 314	KPSL-1248-___		912
<i>24³/₄" (628 mm) H.</i>				
24 x 2 x 24 ³ / ₄	610 x 51 x 628	KPSL-2424-___		949
30 x 2 x 24 ³ / ₄	762 x 51 x 628	KPSL-2430-___		980
36 x 2 x 24 ³ / ₄	914 x 51 x 628	KPSL-2436-___		998
42 x 2 x 24 ³ / ₄	1067 x 51 x 628	KPSL-2442-___		1,133
48 x 2 x 24 ³ / ₄	1219 x 51 x 628	KPSL-2448-___		1,165

At the end of the product code add, in this order: trim color, HPL finishes for sides A/B.

Laminate/fabric combined stackable panels

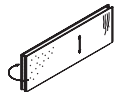

Stackable panel includes in-line junction connectors and side rails. Is installed on top of a monolithic or segmented panel or of a stackable panel of equal width.

		Gr1	Gr2	Gr3
<i>12³/₈" (314 mm) H.</i>				
24 x 2 x 12 ³ / ₈	610 x 51 x 314	KPSC-1224-___	753	776 800
30 x 2 x 12 ³ / ₈	762 x 51 x 314	KPSC-1230-___	771	794 818
36 x 2 x 12 ³ / ₈	914 x 51 x 314	KPSC-1236-___	800	823 847
42 x 2 x 12 ³ / ₈	1067 x 51 x 314	KPSC-1242-___	841	865 888
48 x 2 x 12 ³ / ₈	1219 x 51 x 314	KPSC-1248-___	859	883 906
<i>24³/₄" (628 mm) H.</i>				
24 x 2 x 24 ³ / ₄	610 x 51 x 628	KPSC-2424-___	894	917 941
30 x 2 x 24 ³ / ₄	762 x 51 x 628	KPSC-2430-___	917	941 964
36 x 2 x 24 ³ / ₄	914 x 51 x 628	KPSC-2436-___	941	964 988
42 x 2 x 24 ³ / ₄	1067 x 51 x 628	KPSC-2442-___	1,024	1,047 1,071
48 x 2 x 24 ³ / ₄	1219 x 51 x 628	KPSC-2448-___	1,040	1,064 1,088

At the end of the product code add, in this order: trim color, HPL finish for side A, upholstery for side B.

PANEL COMPONENTS

L-junction kits, full height

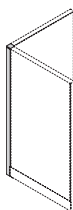

Vertical trim, top cap and 90-degree junction connector included.

W x D x H (in)	W x D x H (mm)	Code	Price (\$)
2 x 2 x 29 ¹ / ₈	51 x 51 x 758	KVPL-30-___	207
2 x 2 x 42 ¹ / ₄	51 x 51 x 1072	KVPL-42-___	230
2 x 2 x 48 ³ / ₈	51 x 51 x 1229	KVPL-48-___	241
2 x 2 x 54 ³ / ₈	51 x 51 x 1386	KVPL-54-___	252
2 x 2 x 66 ⁷ / ₈	51 x 51 x 1700	KVPL-66-___	263

Specify trim color.

T-junction kits, full height

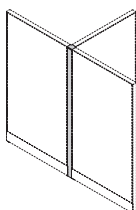

Vertical trim, top cap and 90-degree junction connectors included.

W x D x H (in)	W x D x H (mm)	Code	Price (\$)
2 x 2 x 29 ¹ / ₈	51 x 51 x 758	KVPT-30-___	129
2 x 2 x 42 ¹ / ₄	51 x 51 x 1072	KVPT-42-___	140
2 x 2 x 48 ³ / ₈	51 x 51 x 1229	KVPT-48-___	146
2 x 2 x 54 ³ / ₈	51 x 51 x 1386	KVPT-54-___	151
2 x 2 x 66 ⁷ / ₈	51 x 51 x 1700	KVPT-66-___	162

Specify trim color.

X-junction kits, full height

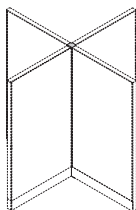

Top cap and 90-degree junction connectors included.

W x D x H (in)	W x D x H (mm)	Code	Price (\$)
2 x 2 x 29 ¹ / ₈	51 x 51 x 758	KVPX-30-___	129
2 x 2 x 42 ¹ / ₄	51 x 51 x 1072	KVPX-42-___	140
2 x 2 x 48 ³ / ₈	51 x 51 x 1229	KVPX-48-___	146
2 x 2 x 54 ³ / ₈	51 x 51 x 1386	KVPX-54-___	151
2 x 2 x 66 ⁷ / ₈	51 x 51 x 1700	KVPX-66-___	162

Specify trim color.

End-of-run trims, full height



End-of-run trim and top cap included. Required at end of each run of panels.

W x D x H (in)	W x D x H (mm)	Code	Price (\$)
2 x 1/2 x 29 ¹ / ₈	51 x 13 x 758	KVET-30-___	183
2 x 1/2 x 42 ¹ / ₄	51 x 13 x 1072	KVET-42-___	194
2 x 1/2 x 48 ³ / ₈	51 x 13 x 1229	KVET-48-___	200
2 x 1/2 x 54 ³ / ₈	51 x 13 x 1386	KVET-54-___	206
2 x 1/2 x 66 ⁷ / ₈	51 x 13 x 1700	KVET-66-___	217

Specify trim color.

L-junction kits, variable height

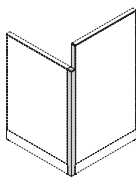

Includes vertical trim, end-of-run trim, top caps and 90-degree junction connector. Dimension in the product code indicates height of tallest panel.

W x D x H (in)	W x D x H (mm)	Code	Price (\$)
2 x 2 x 42 ¹ / ₄	51 x 51 x 1072	KVPLA-42-___	230
2 x 2 x 48 ³ / ₈	51 x 51 x 1229	KVPLA-48-___	241
2 x 2 x 54 ³ / ₈	51 x 51 x 1386	KVPLA-54-___	252
2 x 2 x 66 ⁷ / ₈	51 x 51 x 1700	KVPLA-66-___	263

Specify height of lowest panel. Specify trim color.

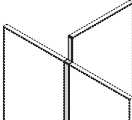
	W x D x H (in)	W x D x H (mm)	Code	Price (\$)
T-junction kits, type A, variable height	<i>Includes vertical trim, end-of-run trim, top caps and 90-degree junction connectors. Dimension in the product code indicates height of tallest panel.</i>			
	2 x 2 x 42 ¹ / ₄	51 x 51 x 1072	KVPTA-42-_-_-	146
	2 x 2 x 48 ³ / ₈	51 x 51 x 1229	KVPTA-48-_-_-	157
	2 x 2 x 54 ⁷ / ₈	51 x 51 x 1386	KVPTA-54-_-_-	162
	2 x 2 x 66 ⁷ / ₈	51 x 51 x 1700	KVPTA-66-_-_-	168
	Specify height of lowest panels. Specify trim color.			

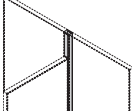
	W x D x H (in)	W x D x H (mm)	Code	Price (\$)
T-junction kits, type B, variable height	<i>Includes vertical trim, top caps and 90-degree junction connectors. Dimension in the product code indicates height of tallest panels.</i>			
	2 x 2 x 42 ¹ / ₄	51 x 51 x 1072	KVPTB-42-_-_-	146
	2 x 2 x 48 ³ / ₈	51 x 51 x 1229	KVPTB-48-_-_-	157
	2 x 2 x 54 ⁷ / ₈	51 x 51 x 1386	KVPTB-54-_-_-	162
	2 x 2 x 66 ⁷ / ₈	51 x 51 x 1700	KVPTB-66-_-_-	168
	Specify height of lowest panel. Specify trim color.			

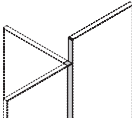
	W x D x H (in)	W x D x H (mm)	Code	Price (\$)
T-junction kits, type C, variable height	<i>Includes vertical trim, end-of-run trim, top caps and 90-degree junction connectors. Dimension in the product code indicates height of tallest panels.</i>			
	2 x 2 x 42 ¹ / ₄	51 x 51 x 1072	KVPTC-42-_-_-	146
	2 x 2 x 48 ³ / ₈	51 x 51 x 1229	KVPTC-48-_-_-	157
	2 x 2 x 54 ⁷ / ₈	51 x 51 x 1386	KVPTC-54-_-_-	162
	2 x 2 x 66 ⁷ / ₈	51 x 51 x 1700	KVPTC-66-_-_-	168
	Specify height of lowest panels. Specify trim color.			

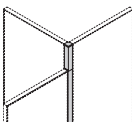
	W x D x H (in)	W x D x H (mm)	Code	Price (\$)
T-junction kits, type D, variable height	<i>Includes vertical trim, top caps and 90-degree junction connectors. Dimension in the product code indicates height of tallest panels.</i>			
	2 x 2 x 42 ¹ / ₄	51 x 51 x 1072	KVPTD-42-_-_-	146
	2 x 2 x 48 ³ / ₈	51 x 51 x 1229	KVPTD-48-_-_-	157
	2 x 2 x 54 ⁷ / ₈	51 x 51 x 1386	KVPTD-54-_-_-	162
	2 x 2 x 66 ⁷ / ₈	51 x 51 x 1700	KVPTD-66-_-_-	168
	Specify height of lowest panel. Specify trim color.			

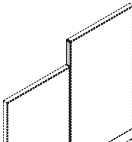
	W x D x H (in)	W x D x H (mm)	Code	Price (\$)
End-of-run trims, variable height	<i>Includes end-of-run trim and top caps. Required for an in-line change of height, a lower laminate gallery panel or with a stackable panel at a workstation end-of-run.</i>			
	2 x 1/2 x 6 ¹ / ₈	51 x 13 x 156	KVETS-6-_-_-	166
	2 x 1/2 x 12 ³ / ₈	51 x 13 x 314	KVETS-12-_-_-	177
	2 x 1/2 x 18 ¹ / ₂	51 x 13 x 472	KVETS-18-_-_-	183
	2 x 1/2 x 24 ³ / ₄	51 x 13 x 628	KVETS-24-_-_-	188
	Specify trim color.			

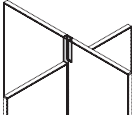
	W x D x H (in)	W x D x H (mm)	Code	Price (\$)
X-junction kits, type A, variable height	<i>Includes vertical trim, top caps and 90-degree junction connectors. Dimension in the product code indicates height of tallest panels.</i>			
	2 x 2 x 42 ¹ / ₄	51 x 51 x 1072	KVPXA-42-_-_-	146
	2 x 2 x 48 ³ / ₈	51 x 51 x 1229	KVPXA-48-_-_-	157
	2 x 2 x 54 ⁷ / ₈	51 x 51 x 1386	KVPXA-54-_-_-	162
	2 x 2 x 66 ⁷ / ₈	51 x 51 x 1700	KVPXA-66-_-_-	168
	Specify height of lowest panels. Specify trim color.			

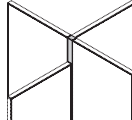
	W x D x H (in)	W x D x H (mm)	Code	Price (\$)
X-junction kits, type B, variable height	<i>Includes vertical trim, top caps and 90-degree junction connectors. Dimension in the product code indicates height of tallest panels.</i>			
	2 x 2 x 42 ¹ / ₄	51 x 51 x 1072	KVPXB-42-_-_-	146
	2 x 2 x 48 ³ / ₈	51 x 51 x 1229	KVPXB-48-_-_-	157
	2 x 2 x 54 ⁷ / ₈	51 x 51 x 1386	KVPXB-54-_-_-	162
	2 x 2 x 66 ⁷ / ₈	51 x 51 x 1700	KVPXB-66-_-_-	168
	Specify height of lowest panel. Specify trim color.			

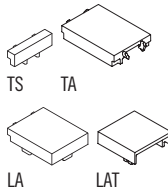
	W x D x H (in)	W x D x H (mm)	Code	Price (\$)
Top caps	<i>Required for certain applications that use center-mounted laminate storage units or transaction countertops; refer to page 7.</i>			
	2 x 3/8 x 1/2	51 x 10 x 14	KVCP-TS-_-_-	47
	2 x 2 1/2 x 1/2	51 x 64 x 14	KVCP-LA-_-_-	47
	2 x 3 x 1/2	51 x 76 x 14	KVCP-TA-_-_-	47
	2 x 3 x 1/2	51 x 76 x 14	KVCP-LAT-_-_-	47
	Specify trim color.			

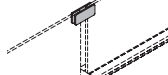
	W x D x H (in)	W x D x H (mm)	Code	Price (\$)
Alignment hardware for glass privacy screens	<i>For use with glass privacy screens (KPGF). To align the top of glass privacy screens in a straight line application (if required). Cannot join two glass privacy screens separated by a junction kit or a laminate intersection gallery panel. Pack of 4.</i>			
	3/8 x 3/4 x 60 ³ / ₄	17 x 19 x 1543	KPGF-ALIGN-S-_-_-	179
	Specify trim color.			

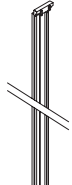
	W x D x H (in)	W x D x H (mm)	Code	Price (\$)
Wall starter	<i>For connecting a run of panels to a structural wall. Includes wall starter and in-line junction connectors. Anchors not included. Note: Wall mounting bracket is shorter than total panel height in order to allow access to raceway.</i>			
	2 x 1/2 x 23 ³ / ₈	51 x 13 x 600	KVWS-30-_-_-	112
	2 x 1/2 x 36	51 x 13 x 914	KVWS-42-_-_-	118
	2 x 1/2 x 42 ¹ / ₈	51 x 13 x 1071	KVWS-48-_-_-	123
	2 x 1/2 x 48 ³ / ₈	51 x 13 x 1228	KVWS-54-_-_-	130
	2 x 1/2 x 60 ³ / ₄	51 x 13 x 1543	KVWS-66-_-_-	130
	Specify trim color.			

	W x D x H (in)	W x D x H (mm)	Code	Price (\$)
Raceway covers	<i>Covers with or without cut-outs for duplex receptacles and communication plates. Pack of 1. To be ordered separately: KVCP-6 covers for unused electrical receptacle cut-outs; refer to page 8.</i>			
	24 x 1/4 x 5	610 x 6 x 127	KVRC-24-_-_-	183
No cut-outs (N)	30 x 1/4 x 5	762 x 6 x 127	KVRC-30-_-_-	194
	36 x 1/4 x 5	914 x 6 x 127	KVRC-36-_-_-	206
	42 x 1/4 x 5	1067 x 6 x 127	KVRC-42-_-_-	217
	48 x 1/4 x 5	1219 x 6 x 127	KVRC-48-_-_-	230
	60 x 1/4 x 5	1524 x 6 x 127	KVRC-60-_-_-	241
	Specify type of cover (N, P, H). Specify trim color.			

	W x D x H (in)	W x D x H (mm)	Code	Price (\$)
Covers for raceway cut-outs	<i>Required for unused duplex and communication receptacle cut-outs. Not compatible with Chicago (H) electrical cut-outs. Pack of 6.</i>			
	3 1/8 x 1/2 x 2 1/8	79 x 13 x 54	KVCP-6-_-_-	78
	Specify trim color.			

ELECTRICITY

IMPORTANT: The electrical components for a 3-circuit, 5-wire system differ from those for a 4-circuit, 8-wire system. These components are not interchangeable from one system to the other. Accordingly, special attention is required during specification. Take note of whether the product code includes the digit '3' or '4'.

ELECTRICAL COMPONENTS – 3-CIRCUIT SYSTEM

	W x D x H (in)	W x D x H (mm)	Code	Price (\$)
Hardwire base feed	<i>Enables connection of electric system to the floor or wall. Connects to electric system at the location of the receptacle. Note: The housing exceeds the raceway by 1½" (38 mm). Check the clearance required before installing storage units.</i>			
	72	1829	KEB3-S-6	270

Plug-in base feed, 20-amp	<i>Enables connection of electric system to a 20-amp outlet. Connects to electric system at the location of the receptacle. Powers circuit No. 1 only. UL Recognized, cUL Approved. Note: The housing exceeds the raceway by 1½" (38 mm). Check the clearance required before installing storage units.</i>			
	24	610	KEB3-P-2	277

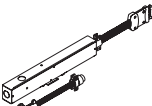
Concealed base feed	<i>Enables connection of electric system to the floor or wall. Meets the standards of the New York City Building Code. Inserts into a non-powered panel and connects in-line to the adjacent panel's electric panel. Mounting brackets included. Note: Requires piercing of raceway cover. A cover with a Type P cut-out may also be ordered separately.</i>			
	72	1829	KEB3-C-6	386

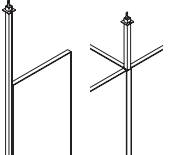
Powered feed poles	<i>Enables connection of electric system and the running of communication cables to a ceiling with a maximum height of 12' (3657 mm). Connects to the end of an electric system. Includes pole, top caps, ceiling cover plate, power feed and a Y connector.</i>			
	<i>To be installed at end of panel run.</i>			
	144	3657	KET3-12-___	1,252
	<i>To be installed on an L, T or X junction kit.</i>			
	114	2895	KET3-9-___	1,114

Specify trim color.
KET3-12 KET3-9

Duplex receptacles, 15-amp	<i>Common ground. Pack of 10.</i>			
	3½ x 1⅞ x 1½	88 x 35 x 45	KER3-C-__	335

Specify type of circuit (1, 2, 3). Specify Black (K) or White (W) color.

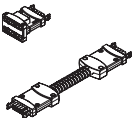
Power connectors for junctions	<i>Required only to power panels separated by a junction kit; refer to page 10. Note: Used as a complement to the electric connector supplied with each powered panel.</i>			
	<i>For L or Type S connection (includes a Y connector).</i>			
			KEJ3-LS	66
	<i>For T connection (includes a Y connector and a junction connector).</i>			
			KEJ3-T	131
	<i>For X connection (includes two Y connectors and two junction connectors).</i>			
			KEJ3-X	160
	<i>For Type G connection (includes a junction connector).</i>			
			KEJ3-G	102

ELECTRICAL COMPONENTS – 4-CIRCUIT SYSTEM

Pass-thru jumper cables for non-powered panel	<i>Required only to connect two panels separated by one or several non-powered panel(s). Connector length is adjustable in order to enable a connection through a junction kit. Note: Connector length is 18" (457 mm) greater than the total width of the panel(s) to be crossed.</i>			
--	---	--	--	--

	24" (610 mm) W panel		KEJL3-24	139
	30" (762 mm) W panel		KEJL3-30	146
	36" (914 mm) W panel		KEJL3-36	153
	42" (1067 mm) W panel		KEJL3-42	160
	48" (1219 mm) W panel(s)		KEJL3-48	168
	60" (1524 mm) W panel(s)		KEJL3-60	183
	66" (1676 mm) W panels		KEJL3-66	206
	72" (1829 mm) W panels		KEJL3-72	225
	78" (1981 mm) W panels		KEJL3-78	244
	84" (2134 mm) W panels		KEJL3-84	263
	90" (2283 mm) W panels		KEJL3-90	282
	96" (2438 mm) W panels		KEJL3-96	301
	102" (2591 mm) W panels		KEJL3-102	320
	108" (2743 mm) W panels		KEJL3-108	339
	120" (3048 mm) W panels		KEJL3-120	358

Electrical retrofit kits	<i>Enables retrofit connection of a non-powered panel. Electric system, in-line junction connector and mounting brackets included.</i>			
---------------------------------	--	--	--	--

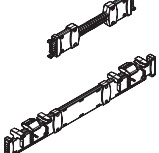
	24" (610 mm) W panel		KEP3-24	189
	30" (762 mm) W panel		KEP3-30	233
	36" (914 mm) W panel		KEP3-36	248
	42" (1067 mm) W panel		KEP3-42	262
	48" (1219 mm) W panel		KEP3-48	270
	60" (1524 mm) W panel		KEP3-60	357

ELECTRICAL COMPONENTS – 4-CIRCUIT SYSTEM

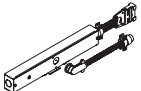

Hardwire base feed	<i>Enables connection of electric system to the floor or wall. Connects to electric system at the location of the receptacle. Note: The housing exceeds the raceway by 1½" (38 mm). Check the clearance required before installing storage units.</i>			
	72	1829	KEB4-S-6	335

Plug-in base feed, 20-amp	<i>Enables connection of electric system to a 20-amp outlet. Connects to electric system at the location of the receptacle. Powers circuit No. 1 only. UL Recognized, cUL Approved. Note: The housing exceeds the raceway by 1½" (38 mm). Check the clearance required before installing storage units.</i>			
	24	610	KEB4-P-2	277

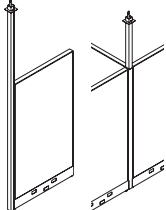
Concealed base feed	<i>Enables connection of electric system to the floor or wall. Meets the standards of the New York City Building Code. Inserts into a non-powered panel and connects in-line to the adjacent panel's electric panel. Mounting brackets included. Note: Requires piercing of raceway cover. A cover with a Type P cut-out may also be ordered separately.</i>			
	72	1829	KEB4-C-6	379

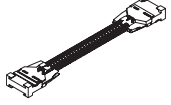

Powered feed poles	<i>Enables connection of electric system and the running of communication cables to a ceiling with a maximum height of 12" (3657 mm). Connects to the end of an electric system. Includes pole, top caps, ceiling cover plate and power feed.</i>			
	<i>To be installed at end of panel run.</i>			
	144	3657	KET4-12-___	1,354
	<i>To be installed on an L, T or X junction kit.</i>			
	114	2895	KET4-9-___	1,216

Specify trim color.
KET4-12 KET4-9

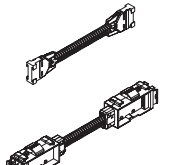
	W x D x H (in)	W x D x H (mm)	Code	Price (\$)
Duplex receptacles, 15-amp 	<i>Common ground. Type D4 receptacle identified by an orange triangle indicates that the circuit is dedicated and isolated. Pack of 10.</i>			
	<i>Common ground.</i>			
	3 1/2 x 1 3/8 x 1 3/8	88 x 35 x 35	KER4-C - _	379
	<i>Isolated and dedicated circuit.</i>			
	3 1/2 x 1 3/8 x 1 3/8	88 x 35 x 35	KER4-D4 - _	379
	Specify type of circuit (1, 2, 3). Specify black (K) or white (W) color.			
Power connectors for junction 	<i>Required only to power panels separated by a junction kit; refer to page 10. For L or Type S connection (includes a junction connector).</i>			
			KEJ4-LS	175
	<i>For T connection (includes two junction connectors).</i>			
			KEJ4-T	320
	<i>For X connection (includes three junction connectors).</i>			
		KEJ4-X	459	
<i>For Type G connection (includes a junction connector).</i>				
		KEJ4-G	175	
Pass-thru jumper cables for non-powered panel 	<i>Required only to connect two panels separated by one or several non-powered panel(s). Connector length is adjustable in order to enable a connection through a junction kit. Note: Pass-thru jumper cables connect to 20" (508 mm) electrical connector supplied with each powered panel.</i>			
	24" (610 mm) W panel		KEJL4-24	183
	30" (762 mm) W panel		KEJL4-30	189
	36" (914 mm) W panel		KEJL4-36	197
	42" (1067 mm) W panel		KEJL4-42	204
	48" (1219 mm) W panel(s)		KEJL4-48	226
	60" (1524 mm) W panel(s)		KEJL4-60	248
	66" (1676 mm) W panels		KEJL4-66	278
	72" (1829 mm) W panels		KEJL4-72	305
	78" (1981 mm) W panels		KEJL4-78	332
	84" (2134 mm) W panels		KEJL4-84	358
	90" (2283 mm) W panels		KEJL4-90	385
	96" (2438 mm) W panels		KEJL4-96	412
102" (2591 mm) W panels		KEJL4-102	439	
108" (2743 mm) W panels		KEJL4-108	466	
120" (3048 mm) W panels		KEJL4-120	493	

Electrical retrofit kits 	<i>Enables retrofit connection of a non-powered panel. Electric system, in-line junction connector and mounting brackets included.</i>			
	24" (610 mm) W panel		KEP4-24	277
	30" (762 mm) W panel		KEP4-30	335
	36" (914 mm) W panel		KEP4-36	372
	42" (1067 mm) W panel		KEP4-42	386
	48" (1219 mm) W panel		KEP4-48	401
	60" (1524 mm) W panel		KEP4-60	422

ELECTRICAL ACCESSORIES

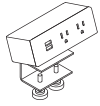
Electrified receptacles for work surface   	<i>Mounts to rear of work surface; no drilling necessary. Pale gray plastic face with anodized aluminum housing. 6" (1829 mm) white cable.</i>			
	<i>2 power outlets.</i>			
	4 x 3 x 3 3/8	102 x 78 x 85	KLGC-PS2P	412
	<i>1 power outlet / 2 USB charging ports.</i>			
	4 x 3 x 3 3/8	102 x 78 x 85	KLGC-PS1USB1P	577
<i>2 power outlets / 2 USB charging ports.</i>				
5 1/2 x 3 x 3 3/8	140 x 78 x 85	KLGC-PS1USB2P	600	

	W x D x H (in)	W x D x H (mm)	Code	Price (\$)
Grommet-mounted receptacle 	<i>1 power outlet / 2 USB charging ports. Liquid-proof. Mounting screw included. Silver. 108" (2743 mm) black cable.</i>			
	3 3/4 x 2 1/4 x 3 3/8	95 x 57 x 79	KLGC-PCQ1USB1P	635

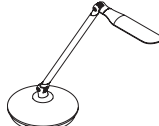
Lamp 	<i>In aluminum and silver plastic. Base with 6" (152 mm) diameter with USB charging port. Dimmer enables control of luminosity from 100% to 5% continuously. 10-hour automatic shut-off. 3500K, 85 CRI, 41 W, 18 LED. ETL certified (UL/CSA equivalent). 36" (914 mm) black cable.</i>			
	7 3/4 x 7 3/4 x 17	197 x 13 x 432	KELB-14USB	964

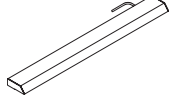
Electronic fluorescent tasklights 	<i>Electronic tubes do not cause interference. T5 - 4100K electronic ballast. 19": 10W, 25": 14W, 37": 21W, 49": 28W. Pivots with a 160-degree range to direct lighting. ETL certified (equivalent to UL/CSA). 108" (2743 mm) cable. Black.</i>			
	18 7/8 x 3 3/8 x 1	480 x 85 x 26	KLGC-T5LE19	329
	24 3/8 x 3 3/8 x 1	626 x 85 x 26	KLGC-T5LE25	365
	36 1/2 x 3 3/8 x 1	927 x 85 x 26	KLGC-T5LE37	405
	48 1/4 x 3 3/8 x 1	1226 x 85 x 26	KLGC-T5LE49	452

Data faceplates for raceway 	<i>Inserts into raceway communication cut-out. Accepts up to 4 interlocking QuickPort adapters and connectors for voice and data applications, sold separately. Also compatible with Keystone connectors. Pack of 2.</i>			
	3 1/8 x 1/2 x 2 5/8	80 x 11 x 42	KEFC-2 - _	112
	Specify black (K) or white (W) color.			

Poles for network cables 	<i>Enables running of communication cables to a ceiling with a maximum height of 12' (3657 mm). Includes pole, top caps and ceiling cover plate.</i>			
	<i>To be installed at end of panel run.</i>			
	144	3657	KETC-12 - _	776
	<i>To be installed on an L, T or X junction kit.</i>			
	114	2895	KETC-9 - _	664

Cable management fasteners 	<i>Facilitates cable management by pinching cables beneath the surface. Grey. Pack of 5.</i>			
	5 1/2 x 1 1/2 x 1	140 x 40 x 25	KLGC-WMC05	141

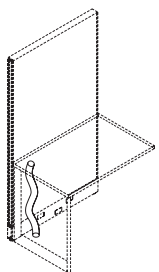
Fabric vertical cable cover 	<i>Enables vertical cable management. 2" (50 mm) diameter. With zipper. Black fabric.</i>			
	2 x 2 x 26	50 x 50 x 660	KEVW-26	106

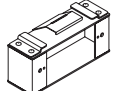
Junction box - Chicago 	<i>Enables a non-powered panel to be adapted to the standards of the Chicago Electric Code. Junction boxes and mounting brackets included. Certain components must be supplied by electrician. To be used with Type H covers; refer to page 28. Pack of 2.</i>			
	4 3/4 x 1 1/2 x 2 1/2	121 x 39 x 65	KEHB-2	246

WORK SURFACE AND SUPPORTS

SURFACES

EXAMPLE: KUCEA-204872-34L-1-G-SNO

CODIFICATION

Series	Type of product	Surface dimension	Option	Orientation	Finish	Grommet	Color	
							Laminate/HPL	
K	UR Rectangular surface		C Curved	L Left	1 Thermofused laminate 1" (25 mm)	N None		
	UC Corner surface		K Straight	R Right	2 High-pressure laminate 1" (25 mm)	G Rectangular grommet		
	UCE Extended corner surface		3 Depth 20" (508 mm)					
			4 Depth 24" (610 mm)					
			5 Depth 30" (762 mm)					

W x D x H (in)	W x D x H (mm)	Code	Laminate (\$)	HPL (\$)
----------------	----------------	------	---------------	----------

WORK SURFACES WITH CABLE DROP

Rectangular surfaces with cable drop clearance at back

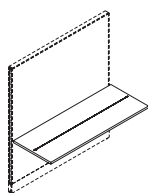

Surfaces with 1" (25 mm) clearance at back for grommet-free cable management. **To be ordered separately:** supports and bases; refer to page 34.

W x D x H (in)	W x D x H (mm)	Code	Laminate (\$)	HPL (\$)
<i>19" (483 mm) D surfaces, 1" (25 mm) clearance at back.</i>				
24 x 19 x 1	610 x 483 x 25	KUR-1924- -N- -	235	324
30 x 19 x 1	762 x 483 x 25	KUR-1930- -N- -	248	358
36 x 19 x 1	914 x 483 x 25	KUR-1936- -N- -	271	389
42 x 19 x 1	1067 x 483 x 25	KUR-1942- -N- -	300	423
48 x 19 x 1	1219 x 483 x 25	KUR-1948- -N- -	324	459
54 x 19 x 1	1372 x 483 x 25	KUR-1954- -N- -	342	494
60 x 19 x 1	1524 x 483 x 25	KUR-1960- -N- -	371	512
66 x 19 x 1	1676 x 483 x 25	KUR-1966- -N- -	412	547
72 x 19 x 1	1829 x 483 x 25	KUR-1972- -N- -	441	594
78 x 19 x 1	1981 x 483 x 25	KUR-1978- -N- -	459	635
84 x 19 x 1	2134 x 483 x 25	KUR-1984- -N- -	470	659
90 x 19 x 1	2286 x 483 x 25	KUR-1990- -N- -	500	694
96 x 19 x 1	2438 x 483 x 25	KUR-1996- -N- -	506	729
<i>23" (585 mm) D surfaces, 1" (25 mm) clearance at back.</i>				
24 x 23 x 1	610 x 585 x 25	KUR-2324- -N- -	288	400
30 x 23 x 1	762 x 585 x 25	KUR-2330- -N- -	311	436
36 x 23 x 1	914 x 585 x 25	KUR-2336- -N- -	335	465
42 x 23 x 1	1067 x 585 x 25	KUR-2342- -N- -	358	506
48 x 23 x 1	1219 x 585 x 25	KUR-2348- -N- -	389	547
54 x 23 x 1	1372 x 585 x 25	KUR-2354- -N- -	405	588
60 x 23 x 1	1524 x 585 x 25	KUR-2360- -N- -	436	612
66 x 23 x 1	1676 x 585 x 25	KUR-2366- -N- -	470	659
72 x 23 x 1	1829 x 585 x 25	KUR-2372- -N- -	512	711
78 x 23 x 1	1981 x 585 x 25	KUR-2378- -N- -	523	688
84 x 23 x 1	2134 x 585 x 25	KUR-2384- -N- -	541	724
90 x 23 x 1	2286 x 585 x 25	KUR-2390- -N- -	570	758
96 x 23 x 1	2438 x 585 x 25	KUR-2396- -N- -	624	852
<i>29" (737 mm) D surfaces, 1" (25 mm) clearance at back.</i>				
24 x 29 x 1	610 x 737 x 25	KUR-2924- -N- -	311	436
30 x 29 x 1	762 x 737 x 25	KUR-2930- -N- -	335	465
36 x 29 x 1	914 x 737 x 25	KUR-2936- -N- -	358	506
42 x 29 x 1	1067 x 737 x 25	KUR-2942- -N- -	389	547
48 x 29 x 1	1219 x 737 x 25	KUR-2948- -N- -	436	594
54 x 29 x 1	1372 x 737 x 25	KUR-2954- -N- -	452	612
60 x 29 x 1	1524 x 737 x 25	KUR-2960- -N- -	470	659
66 x 29 x 1	1676 x 737 x 25	KUR-2966- -N- -	512	711
72 x 29 x 1	1829 x 737 x 25	KUR-2972- -N- -	547	771
78 x 29 x 1	1981 x 737 x 25	KUR-2978- -N- -	570	800
84 x 29 x 1	2134 x 737 x 25	KUR-2984- -N- -	594	836
90 x 29 x 1	2286 x 737 x 25	KUR-2990- -N- -	612	870
96 x 29 x 1	2438 x 737 x 25	KUR-2996- -N- -	653	912

Specify the surface type (1, 2). Specify color.

Rectangular surfaces with cable drop clearance at back and on one side.

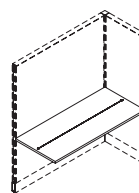

W x D x H (in)	W x D x H (mm)	Code	Laminate (\$)	HPL (\$)
----------------	----------------	------	---------------	----------

Surfaces with 1" (25 mm) clearance at back and an additional 1" (25 mm) clearance for grommet-free cable management. **To be ordered separately:** supports and bases; refer to page 34.

W x D x H (in)	W x D x H (mm)	Code	Laminate (\$)	HPL (\$)
<i>19" (483 mm) D surfaces, 1" (25 mm) clearance at back and on one side.</i>				
23 x 19 x 1	585 x 483 x 25	KUR-1923- -N- -	235	324
29 x 19 x 1	737 x 483 x 25	KUR-1929- -N- -	248	358
35 x 19 x 1	889 x 483 x 25	KUR-1935- -N- -	271	389
41 x 19 x 1	1041 x 483 x 25	KUR-1941- -N- -	300	423
47 x 19 x 1	1194 x 483 x 25	KUR-1947- -N- -	324	459
53 x 19 x 1	1346 x 483 x 25	KUR-1953- -N- -	342	494
59 x 19 x 1	1499 x 483 x 25	KUR-1959- -N- -	371	512
65 x 19 x 1	1651 x 483 x 25	KUR-1965- -N- -	412	547
71 x 19 x 1	1803 x 483 x 25	KUR-1971- -N- -	441	594
77 x 19 x 1	1956 x 483 x 25	KUR-1977- -N- -	459	635
83 x 19 x 1	2108 x 483 x 25	KUR-1983- -N- -	470	659
89 x 19 x 1	2261 x 483 x 25	KUR-1989- -N- -	500	694
95 x 19 x 1	2413 x 483 x 25	KUR-1995- -N- -	506	729
<i>23" (585 mm) D surfaces, 1" (25 mm) clearance at back and on one side.</i>				
23 x 23 x 1	585 x 585 x 25	KUR-2323- -N- -	288	400
29 x 23 x 1	737 x 585 x 25	KUR-2329- -N- -	311	436
35 x 23 x 1	889 x 585 x 25	KUR-2335- -N- -	335	465
41 x 23 x 1	1041 x 585 x 25	KUR-2341- -N- -	358	506
47 x 23 x 1	1194 x 585 x 25	KUR-2347- -N- -	389	547
53 x 23 x 1	1346 x 585 x 25	KUR-2353- -N- -	405	588
59 x 23 x 1	1499 x 585 x 25	KUR-2359- -N- -	436	612
65 x 23 x 1	1651 x 585 x 25	KUR-2365- -N- -	470	659
71 x 23 x 1	1803 x 585 x 25	KUR-2371- -N- -	512	711
77 x 23 x 1	1956 x 585 x 25	KUR-2377- -N- -	523	688
83 x 23 x 1	2108 x 585 x 25	KUR-2383- -N- -	541	724
89 x 23 x 1	2261 x 585 x 25	KUR-2389- -N- -	570	758
95 x 23 x 1	2413 x 585 x 25	KUR-2395- -N- -	624	852
<i>29" (737 mm) D surfaces, 1" (25 mm) clearance at back and on one side.</i>				
23 x 29 x 1	585 x 737 x 25	KUR-2923- -N- -	311	436
29 x 29 x 1	737 x 737 x 25	KUR-2929- -N- -	335	465
35 x 29 x 1	889 x 737 x 25	KUR-2935- -N- -	358	506
41 x 29 x 1	1041 x 737 x 25	KUR-2941- -N- -	389	547
47 x 29 x 1	1194 x 737 x 25	KUR-2947- -N- -	436	594
53 x 29 x 1	1346 x 737 x 25	KUR-2953- -N- -	452	612
59 x 29 x 1	1499 x 737 x 25	KUR-2959- -N- -	470	659
65 x 29 x 1	1651 x 737 x 25	KUR-2965- -N- -	512	711
71 x 29 x 1	1803 x 737 x 25	KUR-2971- -N- -	547	771
77 x 29 x 1	1956 x 737 x 25	KUR-2977- -N- -	570	800
83 x 29 x 1	2108 x 737 x 25	KUR-2983- -N- -	594	836
89 x 29 x 1	2261 x 737 x 25	KUR-2989- -N- -	612	870
95 x 29 x 1	2413 x 737 x 25	KUR-2995- -N- -	653	912

Specify the surface type (1, 2). Specify color.

W x D x H (in)	W x D x H (mm)	Code	Laminate (\$)	HPL (\$)
----------------	----------------	------	---------------	----------

Corner surfaces with cable drop clearance

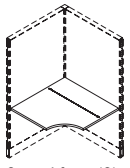

Curved front (C)

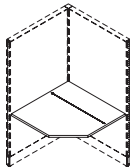
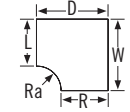

Straight front (K)

Surfaces with 1" (25 mm) clearance on both backs for grommet-free cable management. Curved front (C): radius (Ra) 11 3/4" (300 mm). To be ordered separately: surface supports; refer to page 34.

23" (585 mm) D on left and on right, 1" (25 mm) clearance at both backs.

35 x 35 x 1	889 x 889 x 25	KUC-2335- - -N-S-	488	682
41 x 41 x 1	1041 x 1041 x 25	KUC-2341- - -N-S-	547	788
47 x 47 x 1	1194 x 1194 x 25	KUC-2347- - -N-S-	617	883

29" (737 mm) D surfaces on left and on right, 1" (25 mm) clearance at both backs.

41 x 41 x 1	1041 x 1041 x 25	KUC-2941- - -N-S-	547	788
47 x 47 x 1	1194 x 1194 x 25	KUC-2947- - -N-S-	617	883

Specify surface front (C, K). Specify surface type (1, 2). Diagonal wood grain: change S to D and add \$162 to price. Specify color.

Surface	Straight front (K)
35" (889 mm) D	17" (431 mm)
41" (1041 mm) D	25 1/2" (646 mm)
47" (1194 mm) D	33 7/8" (861 mm)

W x D x H (in)	W x D x H (mm)	Code	Laminate (\$)	HPL (\$)
----------------	----------------	------	---------------	----------

Standard corner surfaces

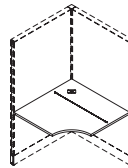

Curved front (C)

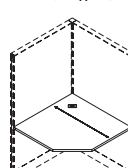
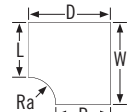

Straight front (K)

Curved front (C): radius (Ra) 11 3/4" (300 mm). To be ordered separately: surface supports; refer to page 34.

24" (610 mm) D surfaces on the left and on the right.

36 x 36 x 1	914 x 914 x 25	KUC-2436- - -S-	517	718
42 x 42 x 1	1067 x 1067 x 25	KUC-2442- - -S-	577	829
48 x 48 x 1	1219 x 1219 x 25	KUC-2448- - -S-	647	930

30" (762 mm) D surfaces on the left and on the right.

42 x 42 x 1	1067 x 1067 x 25	KUC-3042- - -S-	577	829
48 x 48 x 1	1219 x 1219 x 25	KUC-3048- - -S-	647	930

Specify surface front (C, K). Specify the surface type (1, 2). Specify with grommets (G) or no grommets (N). Diagonal wood grain: change S to D and add \$162 to price. Specify color.

Surface	Straight front (K)
35" (889 mm) D	17" (431 mm)
41" (1041 mm) D	25 1/2" (646 mm)
47" (1194 mm) D	33 7/8" (861 mm)

STANDARD WORK SURFACES

Standard rectangular surfaces

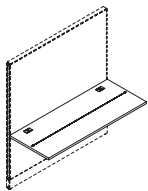

To be ordered separately: supports and bases, refer to page 34.

20" (508 mm) D surfaces.

24 x 20 x 1	610 x 508 x 25	KUR-2024- - -	248	342
30 x 20 x 1	762 x 508 x 25	KUR-2030- - -	264	382
36 x 20 x 1	914 x 508 x 25	KUR-2036- - -	288	412
42 x 20 x 1	1067 x 508 x 25	KUR-2042- - -	318	447
48 x 20 x 1	1219 x 508 x 25	KUR-2048- - -	342	483
54 x 20 x 1	1372 x 508 x 25	KUR-2054- - -	358	517
60 x 20 x 1	1524 x 508 x 25	KUR-2060- - -	389	541
66 x 20 x 1	1676 x 508 x 25	KUR-2066- - -	429	577
72 x 20 x 1	1829 x 508 x 25	KUR-2072- - -	465	629
78 x 20 x 1	1981 x 508 x 25	KUR-2078- - -	483	664
84 x 20 x 1	2134 x 508 x 25	KUR-2084- - -	500	694
90 x 20 x 1	2286 x 508 x 25	KUR-2090- - -	523	729
96 x 20 x 1	2438 x 508 x 25	KUR-2096- - -	535	771

24" (610 mm) D surfaces.

24 x 24 x 1	610 x 610 x 25	KUR-2424- - -	300	423
30 x 24 x 1	762 x 610 x 25	KUR-2430- - -	329	459
36 x 24 x 1	914 x 610 x 25	KUR-2436- - -	353	494
42 x 24 x 1	1067 x 610 x 25	KUR-2442- - -	382	535
48 x 24 x 1	1219 x 610 x 25	KUR-2448- - -	412	570
54 x 24 x 1	1372 x 610 x 25	KUR-2454- - -	429	617
60 x 24 x 1	1524 x 610 x 25	KUR-2460- - -	459	647
66 x 24 x 1	1676 x 610 x 25	KUR-2466- - -	494	694
72 x 24 x 1	1829 x 610 x 25	KUR-2472- - -	535	753
78 x 24 x 1	1981 x 610 x 25	KUR-2478- - -	547	724
84 x 24 x 1	2134 x 610 x 25	KUR-2484- - -	570	758
90 x 24 x 1	2286 x 610 x 25	KUR-2490- - -	600	800
96 x 24 x 1	2438 x 610 x 25	KUR-2496- - -	659	899

30" (762 mm) D surfaces.

24 x 30 x 1	610 x 762 x 25	KUR-3024- - -	329	459
30 x 30 x 1	762 x 762 x 25	KUR-3030- - -	353	494
36 x 30 x 1	914 x 762 x 25	KUR-3036- - -	382	535
42 x 30 x 1	1067 x 762 x 25	KUR-3042- - -	412	570
48 x 30 x 1	1219 x 762 x 25	KUR-3048- - -	459	624
54 x 30 x 1	1372 x 762 x 25	KUR-3054- - -	476	641
60 x 30 x 1	1524 x 762 x 25	KUR-3060- - -	494	694
66 x 30 x 1	1676 x 762 x 25	KUR-3066- - -	535	753
72 x 30 x 1	1829 x 762 x 25	KUR-3072- - -	577	812
78 x 30 x 1	1981 x 762 x 25	KUR-3078- - -	600	841
84 x 30 x 1	2134 x 762 x 25	KUR-3084- - -	624	876
90 x 30 x 1	2286 x 762 x 25	KUR-3090- - -	647	912
96 x 30 x 1	2438 x 762 x 25	KUR-3096- - -	688	959

Specify surface type (1, 2). Specify with grommets (G) or no grommets (N). Specify color.

Corner surfaces extended on left

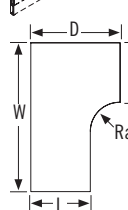
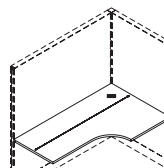

Curved front (C): radius (Ra) 11 3/4" (300 mm). To be ordered separately: surface supports; refer to page 34.

24" (610 mm) D surfaces at both ends.

48 x 36 x 1	1219 x 914 x 25	KUCE-243648-44L- - -	653	912
54 x 36 x 1	1372 x 914 x 25	KUCE-243654-44L- - -	688	946
60 x 36 x 1	1524 x 914 x 25	KUCE-243660-44L- - -	729	1,024
66 x 36 x 1	1676 x 914 x 25	KUCE-243666-44L- - -	788	1,105
72 x 36 x 1	1829 x 914 x 25	KUCE-243672-44L- - -	852	1,194
54 x 42 x 1	1372 x 1067 x 25	KUCE-244254-44L- - -	729	1,000
60 x 42 x 1	1524 x 1067 x 25	KUCE-244260-44L- - -	753	1,053
66 x 42 x 1	1676 x 1067 x 25	KUCE-244266-44L- - -	812	1,141
72 x 42 x 1	1829 x 1067 x 25	KUCE-244272-44L- - -	876	1,229
54 x 48 x 1	1372 x 1219 x 25	KUCE-244854-44L- - -	747	1,029
60 x 48 x 1	1524 x 1219 x 25	KUCE-244860-44L- - -	776	1,088
72 x 48 x 1	1829 x 1219 x 25	KUCE-244872-44L- - -	888	1,247

30" (762 mm) D surfaces at both ends.

54 x 48 x 1	1372 x 1219 x 25	KUCE-304854-55L- - -	747	1,029
60 x 48 x 1	1524 x 1219 x 25	KUCE-304860-55L- - -	776	1,088
72 x 48 x 1	1829 x 1219 x 25	KUCE-304872-55L- - -	888	1,247

Specify surface type (1, 2). Specify with grommets (G) or no grommets (N). Specify color.

Corner surfaces extended on right

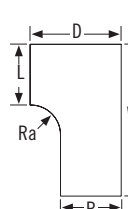
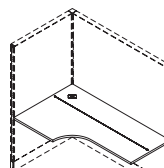

Curved front (C): radius (Ra) 11 3/4" (300 mm). To be ordered separately: surface supports; refer to page 34.

24" (610 mm) D surfaces at both ends.

48 x 36 x 1	1219 x 914 x 25	KUCE-243648-44R- - -	653	912
54 x 36 x 1	1372 x 914 x 25	KUCE-243654-44R- - -	688	946
60 x 36 x 1	1524 x 914 x 25	KUCE-243660-44R- - -	729	1,024
66 x 36 x 1	1676 x 914 x 25	KUCE-243666-44R- - -	788	1,105
72 x 36 x 1	1829 x 914 x 25	KUCE-243672-44R- - -	852	1,194
54 x 42 x 1	1372 x 1067 x 25	KUCE-244254-44R- - -	729	1,000
60 x 42 x 1	1524 x 1067 x 25	KUCE-244260-44R- - -	753	1,053
66 x 42 x 1	1676 x 1067 x 25	KUCE-244266-44R- - -	812	1,141
72 x 42 x 1	1829 x 1067 x 25	KUCE-244272-44R- - -	876	1,229
54 x 48 x 1	1372 x 1219 x 25	KUCE-244854-44R- - -	747	1,029
60 x 48 x 1	1524 x 1219 x 25	KUCE-244860-44R- - -	776	1,088
72 x 48 x 1	1829 x 1219 x 25	KUCE-244872-44R- - -	888	1,247

30" (762 mm) D surfaces at both ends.

54 x 48 x 1	1372 x 1219 x 25	KUCE-304854-55R- - -	747	1,029
60 x 48 x 1	1524 x 1219 x 25	KUCE-304860-55R- - -	776	1,088
72 x 48 x 1	1829 x 1219 x 25	KUCE-304872-55R- - -	888	1,247

Specify surface type (1, 2). Specify with grommets (G) or no grommets (N). Specify color.

W x D x H (in)	W x D x H (mm)	Code	Laminate (\$)	HPL (\$)
Transitional corner surfaces extended on left				
<i>Curved front (C): radius (Ra) 11 3/4" (300 mm). To be ordered separately: surface supports; refer to page 34.</i>				
<i>Surfaces 20" (508 mm) D on left / 24" (610 mm) D on right.</i>				
48 x 36 x 1	1219 x 914 x 25	KUCEA-203648-34L- - -	588	823
54 x 36 x 1	1372 x 914 x 25	KUCEA-203654-34L- - -	624	852
54 x 48 x 1	1372 x 1219 x 25	KUCEA-204854-34L- - -	671	930
60 x 48 x 1	1524 x 1219 x 25	KUCEA-204860-34L- - -	694	977
72 x 48 x 1	1829 x 1219 x 25	KUCEA-204872-34L- - -	800	1,123
<i>Surfaces 24" (610 mm) D on left / 20" (508 mm) D on right.</i>				
48 x 36 x 1	1219 x 914 x 25	KUCEA-243648-43L- - -	588	823
54 x 36 x 1	1372 x 914 x 25	KUCEA-243654-43L- - -	624	852
54 x 48 x 1	1372 x 1219 x 25	KUCEA-244854-43L- - -	671	930
60 x 48 x 1	1524 x 1219 x 25	KUCEA-244860-43L- - -	694	977
72 x 48 x 1	1829 x 1219 x 25	KUCEA-244872-43L- - -	800	1,123
<i>Surfaces 24" (610 mm) D on left / 30" (762 mm) D on right.</i>				
48 x 36 x 1	1219 x 914 x 25	KUCEA-243648-45L- - -	653	912
54 x 36 x 1	1372 x 914 x 25	KUCEA-243654-45L- - -	688	946
54 x 48 x 1	1372 x 1219 x 25	KUCEA-244854-45L- - -	747	1,029
60 x 48 x 1	1524 x 1219 x 25	KUCEA-244860-45L- - -	776	1,088
72 x 48 x 1	1829 x 1219 x 25	KUCEA-244872-45L- - -	888	1,247
<i>Surfaces 30" (762 mm) D on left / 24" (610 mm) D on right.</i>				
48 x 36 x 1	1219 x 914 x 25	KUCEA-303648-54L- - -	653	912
54 x 36 x 1	1372 x 914 x 25	KUCEA-303654-54L- - -	688	946
54 x 48 x 1	1372 x 1219 x 25	KUCEA-304854-54L- - -	747	1,029
60 x 48 x 1	1524 x 1219 x 25	KUCEA-304860-54L- - -	776	1,088
72 x 48 x 1	1829 x 1219 x 25	KUCEA-304872-54L- - -	888	1,247
Specify surface type (1, 2). Specify with grommet (G) or with no grommet (N). Specify color.				

W x D x H (in)	W x D x H (mm)	Code	Laminate (\$)	HPL (\$)
Transitional corner surfaces extended on right				
<i>Curved front (C): radius (Ra) 11 3/4" (300 mm). To be ordered separately: surface supports; refer to page 34.</i>				
<i>Surfaces 20" (508 mm) D on left / 24" (610 mm) D on right.</i>				
48 x 36 x 1	1219 x 914 x 25	KUCEA-203648-34R- - -	588	823
54 x 36 x 1	1372 x 914 x 25	KUCEA-203654-34R- - -	624	852
54 x 48 x 1	1372 x 1219 x 25	KUCEA-204854-34R- - -	671	930
60 x 48 x 1	1524 x 1219 x 25	KUCEA-204860-34R- - -	694	977
72 x 48 x 1	1829 x 1219 x 25	KUCEA-204872-34R- - -	800	1,123
<i>Surfaces 24" (610 mm) D on left / 20" (508 mm) D on right.</i>				
48 x 36 x 1	1219 x 914 x 25	KUCEA-243648-43R- - -	588	823
54 x 36 x 1	1372 x 914 x 25	KUCEA-243654-43R- - -	624	852
54 x 48 x 1	1372 x 1219 x 25	KUCEA-244854-43R- - -	671	930
60 x 48 x 1	1524 x 1219 x 25	KUCEA-244860-43R- - -	694	977
72 x 48 x 1	1829 x 1219 x 25	KUCEA-244872-43R- - -	800	1,123
<i>Surfaces 24" (610 mm) D on left / 30" (762 mm) D on right.</i>				
48 x 36 x 1	1219 x 914 x 25	KUCEA-243648-45R- - -	653	912
54 x 36 x 1	1372 x 914 x 25	KUCEA-243654-45R- - -	688	946
54 x 48 x 1	1372 x 1219 x 25	KUCEA-244854-45R- - -	747	1,029
60 x 48 x 1	1524 x 1219 x 25	KUCEA-244860-45R- - -	776	1,088
72 x 48 x 1	1829 x 1219 x 25	KUCEA-244872-45R- - -	888	1,247
<i>Surfaces 30" (762 mm) D on left / 24" (610 mm) D on right.</i>				
48 x 36 x 1	1219 x 914 x 25	KUCEA-303648-54R- - -	653	912
54 x 36 x 1	1372 x 914 x 25	KUCEA-303654-54R- - -	688	946
54 x 48 x 1	1372 x 1219 x 25	KUCEA-304854-54R- - -	747	1,029
60 x 48 x 1	1524 x 1219 x 25	KUCEA-304860-54R- - -	776	1,088
72 x 48 x 1	1829 x 1219 x 25	KUCEA-304872-54R- - -	888	1,247
Specify surface type (1, 2). Specify with grommets (G) or no grommets (N). Specify color.				

W x D x H (in)	W x D x H (mm)	Code	Laminate (\$)	HPL (\$)
Trapezoidal conference work surfaces				
<i>To be ordered separately: brackets and bases, refer to page 34.</i>				
<i>30" (762 mm) D / 24" (610 mm) W surfaces.</i>				
30 x 48 x 1	762 x 1219 x 25	KUAC-3048- - -	706	912
30 x 54 x 1	762 x 1372 x 25	KUAC-3054- - -	729	935
30 x 60 x 1	762 x 1524 x 25	KUAC-3060- - -	753	1,000
30 x 66 x 1	762 x 1676 x 25	KUAC-3066- - -	805	1,064
30 x 72 x 1	762 x 1829 x 25	KUAC-3072- - -	865	1,147
<i>36" (914 mm) D / 30" (762 mm) W surfaces.</i>				
36 x 48 x 1	914 x 1219 x 25	KUAC-3648- - -	782	1,000
36 x 54 x 1	914 x 1372 x 25	KUAC-3654- - -	800	1,024
36 x 60 x 1	914 x 1524 x 25	KUAC-3660- - -	836	1,105
36 x 66 x 1	914 x 1676 x 25	KUAC-3666- - -	883	1,182
36 x 72 x 1	914 x 1829 x 25	KUAC-3672- - -	935	1,264
Specify surface type (1, 2). Specify with grommet (G) or with no grommet (N). Specify color.				

W x D x H (in)	W x D x H (mm)	Code	Laminate (\$)	HPL (\$)
Rectangular conference work surfaces				
<i>To be ordered separately: brackets and bases, refer to page 34.</i>				
<i>30" (762 mm) W surfaces.</i>				
30 x 48 x 1	762 x 1219 x 25	KURC-3048- - -	594	758
30 x 54 x 1	762 x 1372 x 25	KURC-3054- - -	606	782
30 x 60 x 1	762 x 1524 x 25	KURC-3060- - -	629	836
30 x 66 x 1	762 x 1676 x 25	KURC-3066- - -	671	894
30 x 72 x 1	762 x 1829 x 25	KURC-3072- - -	718	959
<i>36" (914 mm) W surfaces.</i>				
36 x 48 x 1	914 x 1219 x 25	KURC-3648- - -	653	836
36 x 54 x 1	914 x 1372 x 25	KURC-3654- - -	664	852
36 x 60 x 1	914 x 1524 x 25	KURC-3660- - -	694	923
36 x 66 x 1	914 x 1676 x 25	KURC-3666- - -	735	988
36 x 72 x 1	914 x 1829 x 25	KURC-3672- - -	782	1,053
Specify surface type (1, 2). Specify with grommets (G) or no grommets (N). Specify color.				

W x D x H (in)	W x D x H (mm)	Code	Laminate (\$)	HPL (\$)
Rectangular transaction countertops				
<i>Recommended only for use on one or two 42 1/4" (1072 mm) H panels. Brackets included. To be ordered separately: top cap KVCP-__, according to configuration. Refer to page 28.</i>				
<i>Installation on one or two panels.</i>				
24 x 14 x 1	610 x 356 x 25	KUT-1424- -N-	318	412
30 x 14 x 1	762 x 356 x 25	KUT-1430- -N-	342	441
36 x 14 x 1	914 x 356 x 25	KUT-1436- -N-	358	470
42 x 14 x 1	1067 x 356 x 25	KUT-1442- -N-	382	506
48 x 14 x 1	1219 x 356 x 25	KUT-1448- -N-	405	541
<i>Installation on two panels only.</i>				
60 x 14 x 1	1524 x 356 x 25	KUT-1460- -N-	483	635
72 x 14 x 1	1829 x 356 x 25	KUT-1472- -N-	747	876
Specify surface type (1, 2). Specify color.				

W x D x H (in)	W x D x H (mm)	Code	Laminate (\$)	HPL (\$)
Corner transaction countertops				
<i>Recommended only for use on 42 1/4" (1072 mm) H panels. Countertop must match the exact width of the two panels. Brackets included. Radius 13 3/4" (350 mm). To be ordered separately: top cap KVCP-__, according to configuration. Refer to page 28.</i>				
<i>14" (356 mm) D surfaces. Installation on two 24" (610 mm) W panels.</i>				
32 x 32 x 1	813 x 813 x 25	KUTC-1424- -N-	600	788
<i>14" (356 mm) D surfaces. Installation on two 30" (762 mm) W panels.</i>				
38 x 38 x 1	965 x 965 x 25	KUTC-1430- -N-	635	923
<i>14" (356 mm) D surfaces. Installation on two 36" (914 mm) W panels.</i>				
44 x 44 x 1	1118 x 1118 x 25	KUTC-1436- -N-	676	1,082
Specify surface type (1, 2). Specify color.				

	W x D x H (in)	W x D x H (mm)	Code	Price (\$)
--	----------------	----------------	------	------------

WORK SURFACE SUPPORTS

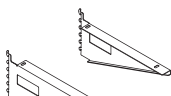
Cantilever supports	<i>Is inserted into lateral rails of panels to support the surfaces. Number of supports required may vary according to configuration; refer to page 13. Black. Pack of 2.</i>			
	1 1/2 x 16 3/4 x 7 1/4	38 x 427 x 183	KACB-P-2	136
	3 3/4 x 16 3/4 x 7 1/4	95 x 427 x 183	KACB-S-2	165

Left/right (P)

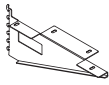

Shared (S), includes a flat bracket

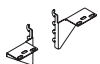
Corner or end brackets	<i>Is inserted into lateral rails of panels to support front or back of surfaces; refer to page 13. Black. Pack of 2 (pair).</i>			
	3 x 4 1/8 x 5	75 x 105 x 126	KAPB-2	53

Flat brackets	<i>Is used to perpendicularly fasten one work surface to another. Black. Pack of 10.</i>			
	5 3/4 x 1 1/2 x 1/4	147 x 38 x 6	KLGC-FLP	106

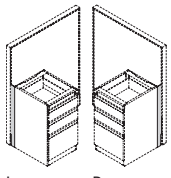
Ped-to-panel attachment fillers	<i>Is used to attach a metal modular pedestal to a panel. May be used with any surface that exceeds pedestal depth by 2 1/8" (54 mm).</i>			
	1 1/8 x 2 3/4 x 27 7/8	30 x 72 x 708	KAPF-L-___	177
	1 1/8 x 2 3/4 x 27 7/8	30 x 72 x 708	KAPF-R-___	177
	Specify trim color.			

L R

Wall tracks	<i>Is used to fasten panel components to structural walls. 2 tracks are the equivalent of 1 panel. Anchor not included. Pack of 2 wall tracks.</i>			
	Note: Wall tracks may be cut at the installation site.			
	5/8 x 3/4 x 60 3/4	17 x 19 x 1543	KAWT-66-2-___	177
	Specify trim color.			

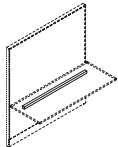
Work surface reinforcement bars	<i>Recommended for certain applications; refer to page 13. Black.</i>			
	<i>For 48" (1219 mm) W surfaces.</i>			
	43 x 1 1/2 x 1 1/2	1092 x 38 x 38	KLGC-BAR43	188
	<i>For 54" et 60" (1372 et 1524 mm) W surfaces.</i>			
	49 x 1 1/2 x 1 1/2	1245 x 38 x 38	KLGC-BAR49	206

WORK SURFACE BASES

Laminate end support panels	<i>Is used to attach a surface to the panel. 2 universal flat brackets allow a left-hand, right-hand or centered installation.</i>			
	1 x 20 x 28	25 x 508 x 711	KAEP-20-___	376
	1 x 24 x 28	25 x 610 x 711	KAEP-24-___	394
	1 x 30 x 28	25 x 762 x 711	KAEP-30-___	441
	Specify color.			

P-metal frames	<i>Is used to attach a surface to the panel. A Silver leg and a cross-bar are included. Compatible with surfaces with a cable drop clearance.</i>			
	2 x 23 3/8 x 28	51 x 600 x 711	KAPL-24-___	318
	2 x 29 3/8 x 28	51 x 752 x 711	KAPL-30-___	324
	Specify installation on left (L) or right (R). Specify accent color for cross-bar: Silver (S) or Snow (W).			

L R

	W x D x H (in)	W x D x H (mm)	Code	Price (\$)
--	----------------	----------------	------	------------

Intermediate P-metal frames

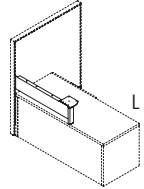
<i>Is used to attach a surface above a low storage module. 1 Silver short leg and a cross-bar are included. Compatible with surfaces with a cable drop clearance.</i>				
	2 x 23 3/8 x 7 3/4	51 x 600 x 198	KAPS-24-___	248
	2 x 29 3/8 x 7 3/4	51 x 752 x 198	KAPS-30-___	253
	Specify installation on left (L) or right (R). Specify accent color for cross-bar: Silver (S) or Snow (W).			

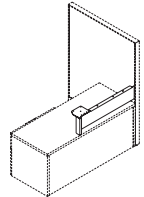
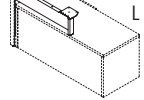

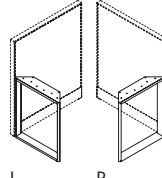

O-metal frames	<i>Is used to attach a surface to the panel. Silver. Not compatible with surfaces with a cable drop clearance.</i>			
	2 x 23 1/2 x 28	51 x 597 x 711	KLGC-LP24P	747
	2 x 29 1/2 x 28	51 x 747 x 711	KLGC-LP30P	788
	Specify installation on left (L) or right (R).			

L R

A-frames	<i>2 Silver leg and a cross-bar included. Not compatible with surfaces with a cable drop clearance.</i>			
	2 x 23 3/8 x 28	51 x 600 x 711	KAAL-24-___	441
	2 x 29 3/8 x 28	51 x 752 x 711	KAAL-30-___	447
	Specify accent color for cross-bar: Silver (S) or Snow (W).			

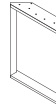
Intermediate A-frames	<i>Is used to support a surface above a low storage module. 2 Silver short legs and a cross-bar are included. Not compatible with surfaces with a cable drop clearance.</i>			
	2 x 23 3/8 x 7 3/4	51 x 600 x 198	KASL-24-___	318
	2 x 29 3/8 x 7 3/4	51 x 752 x 198	KASL-30-___	324
	Specify accent color for cross-bar: Silver (S) or Snow (W).			

O-frames	<i>Silver. Not compatible with surfaces with cable drop clearance.</i>			
	2 x 23 1/2 x 28	51 x 597 x 711	KLGC-LP24	629
	2 x 29 1/2 x 28	51 x 747 x 711	KLGC-LP30	664

I-post, individual	<i>Silver. Square.</i>			
	2 1/2 x 2 1/2 x 28	64 x 64 x 711	KLGC-QTL1	212

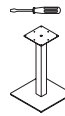
I-post for conference work surface	<i>Silver. Square.</i>			
	17 x 17 x 28	432 x 432 x 711	KLGC-SB17	805

STORAGE UNITS

METAL STORAGE UNITS

CODIFICATION

EXAMPLE: KMPML-1522-1-P53-FOS

Series	Type of product	Front option	Furniture dimension	Drawer option	Metal finishes	
					Trims	Laminate front
K	MSZ Suspended shelf MWZ Wall-mounted shelf MSH Overhead hutch MWH Wall-mounted hutch MPF Modular pedestal MPM Mobile pedestal MPS Personal mobile storage unit	L Laminate		3 Box/box/file 2 File/file 1 Box/file L Concealed box/ access on left R Concealed box/ access on right F Concealed box/ file	P53 Snow P44 Metallic Silver P04 Charcoal P17 Beige	

LAMINATE STORAGE UNITS

EXAMPLE: KLSRB-1236-12-L-SNO-FOS

The first finish will be applied to frame.
The second finish will be applied to front.







CODIFICATION

Series	Type of product	Option	Furniture dimension	Shelf width	Orientation	Laminate finishes	
K	LSO Overhead hutch with flipper door LCS Open center-mounted hutch LCO Center-mounted hutch with sliding door LSR Suspended storage unit with drop-down door LPB Personal storage tower LPW Wardrobe LSP Storage unit with lateral opening compartment LLS Low storage module with drawer and open bookcase	S Shared T Upper shelf B Lower shelf		12 12" (305 mm) 24 24" (610 mm)	L Left R Right	A Rest of product	B Front

	W x D x H (in)	W x D x H (mm)	Code	Price (\$)
--	----------------	----------------	------	------------





METAL STORAGE FURNITURE

Suspended shelves

	W x D x H (in)	W x D x H (mm)	Code	Price (\$)
<i>Panel supports included.</i>				
	24 x 11 ⁷ / ₈ x 4 ⁷ / ₈	610 x 300 x 123	KMSZ-0524	367
	30 x 11 ⁷ / ₈ x 4 ⁷ / ₈	762 x 300 x 123	KMSZ-0530	400
	36 x 11 ⁷ / ₈ x 4 ⁷ / ₈	914 x 300 x 123	KMSZ-0536	413
	42 x 11 ⁷ / ₈ x 4 ⁷ / ₈	1067 x 300 x 123	KMSZ-0542	431
	48 x 11 ⁷ / ₈ x 4 ⁷ / ₈	1219 x 300 x 123	KMSZ-0548	444
	60 x 11 ⁷ / ₈ x 4 ⁷ / ₈	1524 x 300 x 123	KMSZ-0560	498





Specify metal finish.

Wall-mounted shelves

	W x D x H (in)	W x D x H (mm)	Code	Price (\$)
<i>Wall support included. Anchors not included.</i>				
	24 x 11 ⁷ / ₈ x 4 ⁷ / ₈	610 x 300 x 123	KMWZ-0524	624
	30 x 11 ⁷ / ₈ x 4 ⁷ / ₈	762 x 300 x 123	KMWZ-0530	634
	36 x 11 ⁷ / ₈ x 4 ⁷ / ₈	914 x 300 x 123	KMWZ-0536	643
	42 x 11 ⁷ / ₈ x 4 ⁷ / ₈	1067 x 300 x 123	KMWZ-0542	650
	48 x 11 ⁷ / ₈ x 4 ⁷ / ₈	1219 x 300 x 123	KMWZ-0548	659





Specify metal finish.

Overhead hutches with flipper door

	W x D x H (in)	W x D x H (mm)	Code	Price (\$)
<i>Lock. Metal frame and flipper door. Panel supports included.</i>				
	24 x 13 ³ / ₈ x 14	610 x 340 x 356	KMSH-1424	1,012
	30 x 13 ³ / ₈ x 14	762 x 340 x 356	KMSH-1430	1,066
	36 x 13 ³ / ₈ x 14	914 x 340 x 356	KMSH-1436	1,076
	42 x 13 ³ / ₈ x 14	1067 x 340 x 356	KMSH-1442	1,219
	48 x 13 ³ / ₈ x 14	1219 x 340 x 356	KMSH-1448	1,233

Specify metal finish.

Wall-mounted hutches with flipper door



	W x D x H (in)	W x D x H (mm)	Code	Price (\$)
<i>Lock. Metal frame and flipper door. Wall support included. Anchors not included.</i>				
	24 x 13 ³ / ₈ x 14	610 x 340 x 356	KMWH-1424	884
	30 x 13 ³ / ₈ x 14	762 x 340 x 356	KMWH-1430	889
	36 x 13 ³ / ₈ x 14	914 x 340 x 356	KMWH-1436	898
	42 x 13 ³ / ₈ x 14	1067 x 340 x 356	KMWH-1442	931
	48 x 13 ³ / ₈ x 14	1219 x 340 x 356	KMWH-1448	936

Specify metal finish.



Modular pedestals

Enables support of a surface with a depth greater than that of the pedestal. Lock. Suspension bar included with each file drawer. **Note:** Laminate fronts must be assembled at installation site.

Metal frame and fronts.

	W x D x H (in)	W x D x H (mm)	Code	Price (\$)
<i>Box/box/file.</i>				
	15 ¹ / ₄ x 21 ⁷ / ₈ x 27 ³ / ₈	386 x 556 x 701	KMPF-1522-3-	771
Box/box/file	15 ¹ / ₄ x 17 ³ / ₈ x 27 ³ / ₈	386 x 454 x 701	KMPF-1518-3-	771
<i>File/file.</i>				
	15 ¹ / ₄ x 21 ⁷ / ₈ x 27 ³ / ₈	386 x 556 x 701	KMPF-1522-2-	688
File/file	15 ¹ / ₄ x 17 ³ / ₈ x 27 ³ / ₈	386 x 454 x 701	KMPF-1518-2-	688

Metal frame and laminate fronts.



	W x D x H (in)	W x D x H (mm)	Code	Price (\$)
<i>Box/box/file.</i>				
	15 ¹ / ₄ x 21 ⁷ / ₈ x 27 ³ / ₈	386 x 556 x 701	KMPFL-1522-3-	977
Box/box/file	15 ¹ / ₄ x 17 ³ / ₈ x 27 ³ / ₈	386 x 454 x 701	KMPFL-1518-3-	977
<i>File/file.</i>				
	15 ¹ / ₄ x 21 ⁷ / ₈ x 27 ³ / ₈	386 x 556 x 701	KMPFL-1522-2-	876
File/file	15 ¹ / ₄ x 17 ³ / ₈ x 27 ³ / ₈	386 x 454 x 701	KMPFL-1518-2-	876

Specify the metal finish color. For model with laminate fronts, specify finish.



Mobile pedestal

Lock. Suspension bar included with each file drawer. **Note:** Only box/file can accept a cushion (KM CU-15_). Laminate fronts must be assembled at installation site.



Metal frame and fronts.

	W x D x H (in)	W x D x H (mm)	Code	Price (\$)
<i>Box/box/file.</i>				
	15 ¹ / ₄ x 21 ⁷ / ₈ x 26 ⁷ / ₈	386 x 556 x 683	KMPM-1522-3-	888
Box/box/file	15 ¹ / ₄ x 18 ¹ / ₈ x 26 ⁷ / ₈	386 x 479 x 683	KMPM-1519-3-	888
<i>File/file.</i>				
	15 ¹ / ₄ x 21 ⁷ / ₈ x 26 ⁷ / ₈	386 x 556 x 683	KMPM-1522-2-	788
File/file	15 ¹ / ₄ x 18 ¹ / ₈ x 26 ⁷ / ₈	386 x 479 x 683	KMPM-1519-2-	788

Metal frame and laminate fronts.

	W x D x H (in)	W x D x H (mm)	Code	Price (\$)
<i>Box/box/file.</i>				
	15 ¹ / ₄ x 21 ⁷ / ₈ x 26 ⁷ / ₈	386 x 556 x 683	KMPML-1522-3-	1,094
Box/box/file	15 ¹ / ₄ x 18 ¹ / ₈ x 26 ⁷ / ₈	386 x 479 x 683	KMPML-1519-3-	1,094
<i>File/file.</i>				
	15 ¹ / ₄ x 21 ⁷ / ₈ x 26 ⁷ / ₈	386 x 556 x 683	KMPML-1522-2-	977
File/file	15 ¹ / ₄ x 18 ¹ / ₈ x 26 ⁷ / ₈	386 x 479 x 683	KMPML-1519-2-	977

Metal frame and laminate fronts.

	W x D x H (in)	W x D x H (mm)	Code	Price (\$)
<i>Box/box/file.</i>				
	15 ¹ / ₄ x 21 ⁷ / ₈ x 21 ¹ / ₈	386 x 556 x 536	KMPML-1522-1-	870
Box/box/file	15 ¹ / ₄ x 18 ¹ / ₈ x 21 ¹ / ₈	386 x 479 x 536	KMPML-1519-1-	870
<i>File/file.</i>				
	15 ¹ / ₄ x 21 ⁷ / ₈ x 26 ⁷ / ₈	386 x 556 x 683	KMPML-1522-2-	977
File/file	15 ¹ / ₄ x 18 ¹ / ₈ x 26 ⁷ / ₈	386 x 479 x 683	KMPML-1519-2-	977

Specify the metal finish color. For model with laminate fronts, specify finish.

 = ASSEMBLY REQUIRED

	W x D x H (in)	W x D x H (mm)	Code	Price (\$)
Personal mobile storage units	<i>Lock. Concealed box drawer. Note: Can accept a cushion (KMCU-1219). Laminate fronts must be assembled at the installation site.</i>			
	<i>Metal frame and front.</i>			
	12 x 18 ⁷ / ₈ x 20	305 x 479 x 510	KMPS-1219-2-___	865
	<i>Metal frame and laminate front.</i>			
	12 x 18 ⁷ / ₈ x 20	305 x 479 x 510	KMPSL-1219-2-___	970
	Specify access side: left (L), right (R) or file drawer (F). Specify the metal finish color. For model with laminate front, specify finish.			

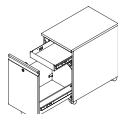

Left (L)

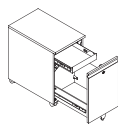

Right (R)

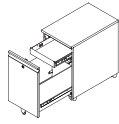

File (F)

	W x D x H (in)	W x D x H (mm)	Code	Price (\$)
Cushions	<i>Is installed on a mobile pedestal or a personal mobile storage unit using self-adhesive strips. Prices shown apply to all Grade 1 and 2 United Chair® fabrics. For other United Chair® grades, add: Grade 3: 15%, Grade 4: 20%, Grade 5: 25% and Grade 6: 30%.</i>			
	15 ¹ / ₄ x 21 ⁷ / ₈ x 7 ¹ / ₈	387 x 556 x 22	KMCU-1522-___	371
	15 ¹ / ₄ x 18 ⁷ / ₈ x 7 ¹ / ₈	387 x 479 x 22	KMCU-1519-___	365
	12 x 18 ⁷ / ₈ x 7 ¹ / ₈	305 x 479 x 22	KMCU-1219-___	358
	Specify cushion upholstery.			



	Code	Price (\$)
Alignment supports	<i>Recommended when several metal hutches and/or shelves are installed side by side. One support is required per two storage units. Pack of 2. Black.</i>	
	KMHZ-ALIGN	35

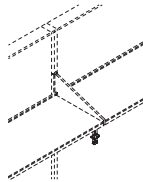

	W x D x H (in)	W x D x H (mm)	Code	Price (\$)
Dividers	<i>For metal hutches and shelves. No tools required. Pack of 3.</i>			
	1 ⁵ / ₈ x 11 x 4 ³ / ₈	43 x 280 x 111	KMHZ-DIV	231
	Specify metal finish.			

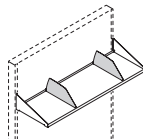

LAMINATE STORAGE FURNITURE				
Overhead hutches with flipper door	<i>Lock. Laminate frame and flipper door. Hardware included.</i>			
	24 x 14 ¹ / ₂ x 16 ¹ / ₈	610 x 366 x 408	KLSO-1624-___	955
	30 x 14 ¹ / ₂ x 16 ¹ / ₈	762 x 366 x 408	KLSO-1630-___	998
	36 x 14 ¹ / ₂ x 16 ¹ / ₈	914 x 366 x 408	KLSO-1636-___	1,042
	42 x 14 ¹ / ₂ x 16 ¹ / ₈	1067 x 366 x 408	KLSO-1642-___	1,102
	48 x 14 ¹ / ₂ x 16 ¹ / ₈	1219 x 366 x 408	KLSO-1648-___	1,155
	Specify laminate finishes A/B.			

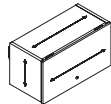

	W x D x H (in)	W x D x H (mm)	Code	Price (\$)
Open center-mounted hutches	<i>Open space(s) with laminate back. Attaches to top of panel. Hardware included. One tone only. To be ordered separately: top cap KVCP-___, according to configuration. Refer to page 28.</i>			
	12⁷/₈" (328 mm) H.			
	<i>Installation on 1 or 2 panels.</i>			
	24 x 14 x 12 ⁷ / ₈	610 x 356 x 328	KLCS-1224-___	841
	30 x 14 x 12 ⁷ / ₈	762 x 356 x 328	KLCS-1230-___	852
	36 x 14 x 12 ⁷ / ₈	914 x 356 x 328	KLCS-1236-___	883
	42 x 14 x 12 ⁷ / ₈	1067 x 356 x 328	KLCS-1242-___	906
	48 x 14 x 12 ⁷ / ₈	1219 x 356 x 328	KLCS-1248-___	1,058
	<i>Installation on 2 panels only.</i>			
	60 x 14 x 12 ⁷ / ₈	1524 x 356 x 328	KLCS-1260-___	1,111
	72 x 14 x 12 ⁷ / ₈	1829 x 356 x 328	KLCS-1272-___	1,182

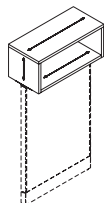

24" to 42"
(610 to 1067 mm)

	W x D x H (in)	W x D x H (mm)	Code	Price (\$)
Open center-mounted hutches (cont'd)	15" (381 mm) H.			
	<i>Installation on 1 or 2 panels.</i>			
	24 x 14 x 15	610 x 356 x 381	KLCS-1524-___	847
	30 x 14 x 15	762 x 356 x 381	KLCS-1530-___	870
	36 x 14 x 15	914 x 356 x 381	KLCS-1536-___	899
	42 x 14 x 15	1067 x 356 x 381	KLCS-1542-___	923
	48 x 14 x 15	1219 x 356 x 381	KLCS-1548-___	1,076
	<i>Installation on 2 panels only.</i>			
	60 x 14 x 15	1524 x 356 x 381	KLCS-1560-___	1,135
	72 x 14 x 15	1829 x 356 x 381	KLCS-1572-___	1,205
	Specify the laminate finish.			

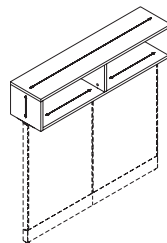

48" to 72"
(1219 to 1829 mm)

	W x D x H (in)	W x D x H (mm)	Code	Price (\$)
Shared open center-mounted storage units	<i>Open space with laminate back. Attaches to top of panel. Hardware included. One tone only. To be ordered separately: top cap KVCP-___, according to configuration. Refer to page 28.</i>			
	12⁷/₈" (328 mm) H.			
	<i>Installation on 1 or 2 panels.</i>			
	42 x 14 x 12 ⁷ / ₈	1067 x 356 x 328	KLCS-1242-___	1,100
	48 x 14 x 12 ⁷ / ₈	1219 x 356 x 328	KLCS-1248-___	1,141
	<i>Installation on 2 panels only.</i>			
	60 x 14 x 12 ⁷ / ₈	1524 x 356 x 328	KLCS-1260-___	1,158
	72 x 14 x 12 ⁷ / ₈	1829 x 356 x 328	KLCS-1272-___	1,235
	15" (381 mm) H.			
	<i>Installation on 1 or 2 panels.</i>			
	42 x 14 x 15	1067 x 356 x 381	KLCS-1542-___	1,118
	48 x 14 x 15	1219 x 356 x 381	KLCS-1548-___	1,158
	<i>Installation on 2 panels only.</i>			
	60 x 14 x 15	1524 x 356 x 381	KLCS-1560-___	1,176
	72 x 14 x 15	1829 x 356 x 381	KLCS-1572-___	1,252
	Specify side for open storage unit: left (L) or right (R). Specify laminate finish.			

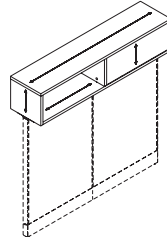

	W x D x H (in)	W x D x H (mm)	Code	Price (\$)
Center-mounted hutches with sliding door	<i>Open spaces with sliding door and laminate back. Attaches to top of panel. Hardware included. To be ordered separately: top cap KVCP-___, according to configuration. Refer to page 28.</i>			
	12⁷/₈" (328 mm) H.			
	<i>Installation on 1 or 2 panels.</i>			
	36 x 14 ³ / ₄ x 12 ⁷ / ₈	914 x 375 x 328	KLCO-1236-___	1,382
	42 x 14 ³ / ₄ x 12 ⁷ / ₈	1067 x 375 x 328	KLCO-1242-___	1,406
	48 x 14 ³ / ₄ x 12 ⁷ / ₈	1219 x 375 x 328	KLCO-1248-___	1,565
	<i>Installation on 2 panels only.</i>			
	60 x 14 ³ / ₄ x 12 ⁷ / ₈	1524 x 375 x 328	KLCO-1260-___	1,628
	72 x 14 ³ / ₄ x 12 ⁷ / ₈	1829 x 375 x 328	KLCO-1272-___	1,723
	15" (381 mm) H.			
	<i>Installation on 1 or 2 panels.</i>			
	36 x 14 ³ / ₄ x 15	914 x 375 x 381	KLCO-1536-___	1,400
	42 x 14 ³ / ₄ x 15	1067 x 375 x 381	KLCO-1542-___	1,417
	48 x 14 ³ / ₄ x 15	1219 x 375 x 381	KLCO-1548-___	1,588
	<i>Installation on 2 panels only.</i>			
	60 x 14 ³ / ₄ x 15	1524 x 375 x 381	KLCO-1560-___	1,652
	72 x 14 ³ / ₄ x 15	1829 x 375 x 381	KLCO-1572-___	1,753
	Specify laminate finishes A/B.			

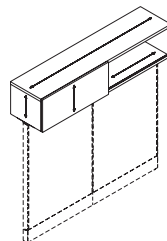

	W x D x H (in)	W x D x H (mm)	Code	Price (\$)
Shared center-mounted hutches with sliding doors	<i>Open spaces with sliding doors and laminate back on both sides. Attaches to top of panel. Hardware included. To be ordered separately: top cap KVCP-___, according to configuration. Refer to page 28.</i>			
	12⁷/₈" (328 mm) H.			
	<i>Installation on 1 or 2 panels.</i>			
	42 x 14 ³ / ₄ x 12 ⁷ / ₈	1067 x 375 x 328	KLCS-1242-___	2,135
	48 x 14 ³ / ₄ x 12 ⁷ / ₈	1219 x 375 x 328	KLCS-1248-___	2,216
	<i>Installation on 2 panels only.</i>			
	60 x 14 ³ / ₄ x 12 ⁷ / ₈	1524 x 375 x 328	KLCS-1260-___	2,223
	72 x 14 ³ / ₄ x 12 ⁷ / ₈	1829 x 375 x 328	KLCS-1272-___	2,370

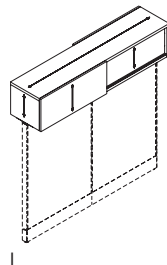

L

	W x D x H (in)	W x D x H (mm)	Code	Laminate (\$)	HPL (\$)
Shared center-mounted hutches with sliding doors(cont'd)	15" (381 mm) H.				
	<i>Installation on 1 or 2 panels.</i>				
	42 x 14 ¹ / ₂ x 15	1067 x 375 x 381	KLCOS-1542-	-	2,169
	48 x 14 ¹ / ₂ x 15	1219 x 375 x 381	KLCOS-1548-	-	2,252
	<i>Installation on 2 panels only.</i>				
	60 x 14 ¹ / ₂ x 15	1524 x 375 x 381	KLCOS-1560-	-	2,264
	72 x 14 ¹ / ₂ x 15	1829 x 375 x 381	KLCOS-1572-	-	2,411

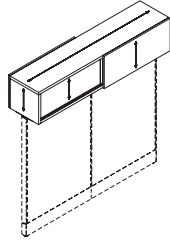

R

	W x D x H (in)	W x D x H (mm)	Code	Laminate (\$)	HPL (\$)
Suspended storage units with drop-down door	<i>Assisted-opening door. Lock. Open space with back. Storage units 42" (1067 mm) W or greater have a central divider.</i>				
	24 x 14 ¹ / ₂ x 12 ³ / ₈	610 x 368 x 314	KLSR-1224-	-	1,341
	30 x 14 ¹ / ₂ x 12 ³ / ₈	762 x 368 x 314	KLSR-1230-	-	1,388
	36 x 14 ¹ / ₂ x 12 ³ / ₈	914 x 368 x 314	KLSR-1236-	-	1,435
	42 x 14 ¹ / ₂ x 12 ³ / ₈	1067 x 368 x 314	KLSR-1242-	-	1,487
	48 x 14 ¹ / ₂ x 12 ³ / ₈	1219 x 368 x 314	KLSR-1248-	-	1,534
	60 x 14 ¹ / ₂ x 12 ³ / ₈	1524 x 368 x 314	KLSR-1260-	-	1,628

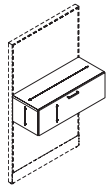

	W x D x H (in)	W x D x H (mm)	Code	Laminate (\$)	HPL (\$)
Suspended storage units with drop-down door and upper shelf	<i>Assisted-opening door. Lock. Open space with back. Flat brackets for fastening to a work surface are included. Storage units 42" (1067 mm) W or greater have a central divider.</i>				
	<i>12" (305 mm) W shelf.</i>				
	36 x 14 ¹ / ₂ x 12 ³ / ₈	914 x 368 x 314	KLSRT-1224-12-	-	1,376 1,511
	42 x 14 ¹ / ₂ x 12 ³ / ₈	1067 x 368 x 314	KLSRT-1230-12-	-	1,429 1,570
	48 x 14 ¹ / ₂ x 12 ³ / ₈	1219 x 368 x 314	KLSRT-1236-12-	-	1,476 1,623
	54 x 14 ¹ / ₂ x 12 ³ / ₈	1372 x 368 x 314	KLSRT-1242-12-	-	1,529 1,682
	60 x 14 ¹ / ₂ x 12 ³ / ₈	1524 x 368 x 314	KLSRT-1248-12-	-	1,576 1,735
	72 x 14 ¹ / ₂ x 12 ³ / ₈	1829 x 368 x 314	KLSRT-1260-12-	-	1,676 1,847
	<i>24" (610 mm) W shelf.</i>				
	48 x 14 ¹ / ₂ x 12 ³ / ₈	1219 x 368 x 314	KLSRT-1224-24-	-	1,424 1,558

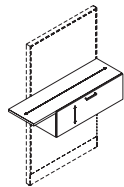

L

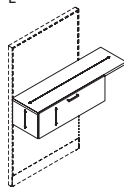

R

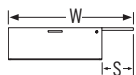

	W x D x H (in)	W x D x H (mm)	Code	Laminate (\$)	HPL (\$)
Suspended storage units with drop-down door and lower shelf	<i>Assisted-opening door. Lock. Open space with back. Shelf may require a reinforcement or support. Storage units 42" (1067 mm) W or greater have a central divider.</i>				
	<i>12" (305 mm) W shelf.</i>				
	36 x 14 ¹ / ₂ x 12 ³ / ₈	914 x 368 x 314	KLSRB-1224-12-	-	1,376
	42 x 14 ¹ / ₂ x 12 ³ / ₈	1067 x 368 x 314	KLSRB-1230-12-	-	1,429
	48 x 14 ¹ / ₂ x 12 ³ / ₈	1219 x 368 x 314	KLSRB-1236-12-	-	1,476
	54 x 14 ¹ / ₂ x 12 ³ / ₈	1372 x 368 x 314	KLSRB-1242-12-	-	1,529
	60 x 14 ¹ / ₂ x 12 ³ / ₈	1524 x 368 x 314	KLSRB-1248-12-	-	1,576
	72 x 14 ¹ / ₂ x 12 ³ / ₈	1829 x 368 x 314	KLSRB-1260-12-	-	1,676
	<i>24" (610 mm) W shelf.</i>				
	48 x 14 ¹ / ₂ x 12 ³ / ₈	1219 x 368 x 314	KLSRB-1224-24-	-	1,424

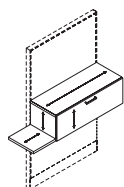

L

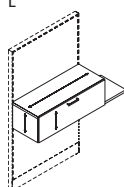

R

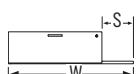

	W x D x H (in)	W x D x H (mm)	Code	Price (\$)
Modular lateral files	<i>Is used to support a surface whose depth is equal to or greater than that of the file. Lock. Suspension bar included with each file drawer.</i>			
	29 ¹ / ₂ x 20 x 28	748 x 508 x 711	KLLF-2030-	1,652
	35 ³ / ₈ x 20 x 28	898 x 508 x 711	KLLF-2036-	1,688

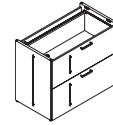

	W x D x H (in)	W x D x H (mm)	Code	Price (\$)
Modular bookcases	<i>Is used to support a surface whose depth is equal to or greater than that of the bookcase. Lock. Adjustable shelf.</i>			
	29 ¹ / ₂ x 19 ¹ / ₄ x 28	748 x 488 x 711	KLBE-2030-	1,100
	35 ³ / ₈ x 19 ¹ / ₄ x 28	898 x 488 x 711	KLBE-2036-	1,188

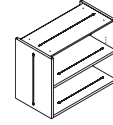

	W x D x H (in)	W x D x H (mm)	Code	Price (\$)
Modular bookcases with doors	<i>Is used to support a surface whose depth is equal to or greater than that of the bookcase. Lock. Adjustable shelf. Lock.</i>			
	29 ¹ / ₂ x 20 x 28	748 x 508 x 711	KLBI-2030-	1,306
	35 ³ / ₈ x 20 x 28	898 x 508 x 711	KLBI-2036-	1,353

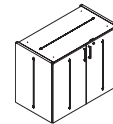

	W x D x H (in)	W x D x H (mm)	Code	Price (\$)
Modular bookcases with door	<i>Is used to support a surface whose depth is equal to or greater than that of the bookcase. Lock. Adjustable shelf. Lock.</i>			
	18 x 20 x 28	457 x 508 x 711	KLBF-2018-	1,058

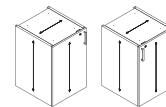

L

R

	W x D x H (in)	W x D x H (mm)	Code	Price (\$)
Personal storage towers with bookcase / wardrobe	<i>1 box drawer and 2 file drawers. Suspension bars. Pencil tray. Clothes hanger bar and fixed shelf. Adjustable shelf on bookcase side on models 54" (1372 mm) and 66³/₈" (1686 mm) H.</i>			
	<i>Wardrobe on left, bookcase on right.</i>			
	24 x 24 x 47 ⁷ / ₈	610 x 610 x 1215	KLPB-242448-L-	2,670
	24 x 24 x 54	610 x 610 x 1372	KLPB-242454-L-	2,822
	24 x 24 x 66 ³ / ₈	610 x 610 x 1686	KLPB-242466-L-	2,976
	<i>Wardrobe on right, bookcase on left.</i>			
	24 x 24 x 47 ⁷ / ₈	610 x 610 x 1215	KLPB-242448-R-	2,670
	24 x 24 x 54	610 x 610 x 1372	KLPB-242454-R-	2,822
	24 x 24 x 66 ³ / ₈	610 x 610 x 1686	KLPB-242466-R-	2,976

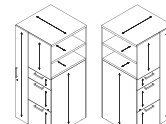

L

R

	W x D x H (in)	W x D x H (mm)	Code	Price (\$)
Wardrobes	<i>Clothes hanger bar. Lock. Models 48" (1219 mm) H and greater have a fixed shelf.</i>			
	<i>12" (305 mm) W.</i>			
	12 x 24 x 41 ³ / ₈	305 x 610 x 1058	KLPW-241242-	1,840
	12 x 24 x 47 ⁷ / ₈	305 x 610 x 1215	KLPW-241248-	1,894
	12 x 24 x 54	305 x 610 x 1372	KLPW-241254-	1,941
	12 x 24 x 66 ³ / ₈	305 x 610 x 1686	KLPW-241266-	1,988
	<i>15" (381 mm) W.</i>			
	15 x 24 x 41 ³ / ₈	381 x 610 x 1058	KLPW-241542-	1,934
	15 x 24 x 47 ⁷ / ₈	381 x 610 x 1215	KLPW-241548-	1,994
	15 x 24 x 54	381 x 610 x 1372	KLPW-241554-	2,046
15 x 24 x 66 ³ / ₈	381 x 610 x 1686	KLPW-241566-	2,093	



L

R

Specify door opening: hinges on left (L) or hinges on right (R). Specify laminate finishes A/B.

	W x D x H (in)	W x D x H (mm)	Code	Price (\$)
Storage units with lateral opening compartment	<i>Compartment with door and an adjustable shelf. Lock. Model 30" (762 mm) in depth includes a wardrobe space with a clothes hook. Models 54" (1372 mm) H have an additional fixed shelf.</i>			
	<i>12" (305 mm) W.</i>			
	12 x 24 x 41 ⁵ / ₈	305 x 610 x 1058	KLSP-122442-_-_-	2,399
	12 x 24 x 47 ⁷ / ₈	305 x 610 x 1215	KLSP-122448-_-_-	2,535
	12 x 24 x 54	305 x 610 x 1372	KLSP-122454-_-_-	2,676
	12 x 30 x 41 ⁵ / ₈	305 x 762 x 1058	KLSP-123042-_-_-	2,558
	12 x 30 x 47 ⁷ / ₈	305 x 762 x 1215	KLSP-123048-_-_-	2,629
	12 x 30 x 54	305 x 762 x 1372	KLSP-123054-_-_-	2,705
	<i>15" (381 mm) W.</i>			
	15 x 24 x 41 ⁵ / ₈	381 x 610 x 1058	KLSP-152442-_-_-	2,535
15 x 24 x 47 ⁷ / ₈	381 x 610 x 1215	KLSP-152448-_-_-	2,611	
15 x 24 x 54	381 x 610 x 1372	KLSP-152454-_-_-	2,687	
15 x 30 x 41 ⁵ / ₈	381 x 762 x 1058	KLSP-153042-_-_-	2,623	
15 x 30 x 47 ⁷ / ₈	381 x 762 x 1215	KLSP-153048-_-_-	2,694	
15 x 30 x 54	381 x 762 x 1372	KLSP-153054-_-_-	2,764	
	Specify access side: left (L) or right (R). Specify laminate finishes A/B.			
Shared low storage units with drawers	<i>1 box drawer and 1 file drawer per side. Suspension bars. Pencil trays. Locks. Accommodates one or two cushions (KLCU-__20); refer to page 38.</i>			
	47 ¹ / ₄ x 20 x 20 ¹ / ₄	1200 x 508 x 513	KLSS-204820-_-_-	2,893
	59 x 20 x 20 ¹ / ₄	1500 x 508 x 513	KLSS-206020-_-_-	3,052
	70 ¹ / ₈ x 20 x 20 ¹ / ₄	1800 x 508 x 513	KLSS-207220-_-_-	3,204
	Specify laminate finishes A/B.			

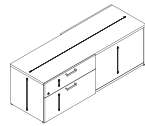
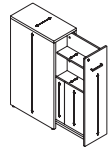
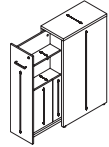

	W x D x H (in)	W x D x H (mm)	Code	Price (\$)
Low storage modules with drawers and open bookcase	<i>1 box drawer and 1 file drawer. Suspension bar. Pencil tray. Lock. Open bookcase with back. Adjustable shelf. Can accept one or two cushions (KLCU-__20); refer to page 38.</i>			
	47 ¹ / ₄ x 20 x 20 ¹ / ₄	1200 x 508 x 513	KLLS-204820-_-_-	2,552
	59 x 20 x 20 ¹ / ₄	1500 x 508 x 513	KLLS-206020-_-_-	2,600
	70 ¹ / ₈ x 20 x 20 ¹ / ₄	1800 x 508 x 513	KLLS-207220-_-_-	2,723
	Specify open side of bookcase: left (L) or right (R). Specify laminate finishes A/B.			
Cushions for laminate low storage modules	<i>Is installed on a low storage module using self-adhesive strips. Prices shown apply to all Grade 1 and 2 United Chair® fabrics. For other United Chair® grades, add: Grade 3: 15%, Grade 4: 20%, Grade 5: 25% and Grade 6: 30%.</i>			
	23 ³ / ₈ x 19 ¹ / ₄ x 7 ¹ / ₈	600 x 490 x 22	KLCU-2420-_-_-	376
	29 ¹ / ₂ x 19 ¹ / ₄ x 7 ¹ / ₈	750 x 490 x 22	KLCU-3020-_-_-	394
	35 ³ / ₈ x 19 ¹ / ₄ x 7 ¹ / ₈	900 x 490 x 22	KLCU-3620-_-_-	412
	Specify cushion upholstery.			

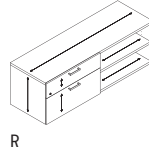
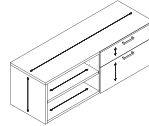

ACCESSORIES

Accessory rails	<i>Is inserted into the lateral rails on a panel.</i>		
	23 ⁵ / ₈ x 1/2 x 1 1/2	593 x 11 x 38	KKAR-24-_-_- 224
	29 ³ / ₈ x 1/2 x 1 1/2	745 x 11 x 38	KKAR-30-_-_- 235
	35 ³ / ₈ x 1/2 x 1 1/2	897 x 11 x 38	KKAR-36-_-_- 241
	41 ³ / ₈ x 1/2 x 1 1/2	1050 x 11 x 38	KKAR-42-_-_- 248
	47 ³ / ₈ x 1/2 x 1 1/2	1202 x 11 x 38	KKAR-48-_-_- 259
	59 ³ / ₈ x 1/2 x 1 1/2	1507 x 11 x 38	KKAR-60-_-_- 264
	Specify trim color.		

All-purpose trays	<i>Metal. Compatible with all Lacasse accessory rails. Pack of 2.</i>		
	12 x 3 ³ / ₄ x 1 ¹ / ₈	305 x 96 x 30	KKAT-RAST2-_-_- 194
	Specify trim color.		

Vertical paper trays	<i>Metal. Compatible with all Lacasse accessory rails. Pack of 2.</i>		
	11 ³ / ₄ x 2 ⁵ / ₈ x 8	300 x 68 x 203	KKAT-RVPT11-_-_- 306
	Specify trim color.		

Horizontal paper trays	<i>Metal. Compatible with all Lacasse accessory rails. Pack of 2.</i>		
	<i>Letter format.</i>		
	12 x 9 ⁷ / ₈ x 2	305 x 251 x 50	KKAT-RPT11-_-_- 241
	<i>Legal format.</i>		
	14 x 9 ⁷ / ₈ x 2	375 x 251 x 50	KKAT-RPT14-_-_- 259
	Specify trim color.		

Tackboards	<i>Is inserted into the lateral rails on a panel. Not required for fabric acoustical panels. Prices shown apply to all Grade 1 and 2 United Chair® fabrics (except vinyl and leather). For other United Chair® grades, add: Grade 3: 15%, Grade 4: 20%, Grade 5: 25% and Grade 6: 30%.</i>			
	<i>6¹/₈" (157 mm) H.</i>			
	23 ⁵ / ₈ x 3/8 x 6 ¹ / ₈	593 x 10 x 157	KKATB-0624-_-_-	347
	29 ³ / ₈ x 3/8 x 6 ¹ / ₈	745 x 10 x 157	KKATB-0630-_-_-	365
	35 ³ / ₈ x 3/8 x 6 ¹ / ₈	897 x 10 x 157	KKATB-0636-_-_-	382
	41 ³ / ₈ x 3/8 x 6 ¹ / ₈	1050 x 10 x 157	KKATB-0642-_-_-	400
	47 ³ / ₈ x 3/8 x 6 ¹ / ₈	1202 x 10 x 157	KKATB-0648-_-_-	418
	<i>12³/₈" (314 mm) H.</i>			
	23 ⁵ / ₈ x 3/8 x 12 ³ / ₈	593 x 10 x 314	KKATB-1224-_-_-	371
	29 ³ / ₈ x 3/8 x 12 ³ / ₈	745 x 10 x 314	KKATB-1230-_-_-	394
	35 ³ / ₈ x 3/8 x 12 ³ / ₈	897 x 10 x 314	KKATB-1236-_-_-	418
	41 ³ / ₈ x 3/8 x 12 ³ / ₈	1050 x 10 x 314	KKATB-1242-_-_-	441
	47 ³ / ₈ x 3/8 x 12 ³ / ₈	1202 x 10 x 314	KKATB-1248-_-_-	465
	Specify panel upholstery.			









Whiteboards	<i>Folded metal. Is inserted into a panel's lateral rails. High-gloss white finish for dry-erase markers. Magnetic.</i>			
	<i>12³/₈" (314 mm) H.</i>			
	23 ⁵ / ₈ x 3/8 x 12 ³ / ₈	593 x 10 x 314	KKAMB-1224-_-_-	212
	29 ³ / ₈ x 3/8 x 12 ³ / ₈	745 x 10 x 314	KKAMB-1230-_-_-	224
	35 ³ / ₈ x 3/8 x 12 ³ / ₈	897 x 10 x 314	KKAMB-1236-_-_-	253
	41 ³ / ₈ x 3/8 x 12 ³ / ₈	1050 x 10 x 314	KKAMB-1242-_-_-	264
	47 ³ / ₈ x 3/8 x 12 ³ / ₈	1202 x 10 x 314	KKAMB-1248-_-_-	282
	59 ³ / ₈ x 3/8 x 12 ³ / ₈	1507 x 10 x 314	KKAMB-1260-_-_-	488
	<i>24³/₄" (628 mm) H.</i>			
	23 ⁵ / ₈ x 3/8 x 24 ³ / ₄	593 x 10 x 628	KKAMB-2424-_-_-	295
	29 ³ / ₈ x 3/8 x 24 ³ / ₄	745 x 10 x 628	KKAMB-2430-_-_-	371
	35 ³ / ₈ x 3/8 x 24 ³ / ₄	897 x 10 x 628	KKAMB-2436-_-_-	394
	41 ³ / ₈ x 3/8 x 24 ³ / ₄	1050 x 10 x 628	KKAMB-2442-_-_-	423
	47 ³ / ₈ x 3/8 x 24 ³ / ₄	1202 x 10 x 628	KKAMB-2448-_-_-	476
	59 ³ / ₈ x 3/8 x 24 ³ / ₄	1507 x 10 x 628	KKAMB-2460-_-_-	805

Shelves	<i>Is inserted into a panel's side rails. Brackets included.</i>			
	24 x 7 x 1	610 x 177 x 25	KKAS-24-_-_-	288
	30 x 7 x 1	762 x 177 x 25	KKAS-30-_-_-	300
	36 x 7 x 1	914 x 177 x 25	KKAS-36-_-_-	306
	Specify trim color. Specify the laminate finish.			

Modesty panels	<i>Provides a visual barrier beneath a work surface. Support has a Silver finish. Is fastened beneath a surface with a clearance equal to or greater than the width of the modesty panel.</i>			
	30 x 3/8 x 12	761 x 16 x 305	KKML-1230-_-_-	441
	36 x 3/8 x 12	913 x 16 x 305	KKML-1236-_-_-	488
	42 x 3/8 x 12	1065 x 16 x 305	KKML-1242-_-_-	564
	Specify the laminate finish.			

Trays for metal pedestals	<i>Made of black plastic. Is placed along the sides of a box drawer. Compatible only with 15¹/₄" (386 mm) W pedestals.</i>			
	<i>Model with 4 compartments.</i>			
	12 ³ / ₄ x 5 ¹ / ₂ x 1	325 x 142 x 25	KKPHU-6-_-_-	88
	<i>Model with 2 compartments.</i>			
	12 ¹ / ₈ x 3 x 1	327 x 76 x 25	KKPHU-3-_-_-	41

Dividers for metal pedestals	<i>Made of black plastic. Is inserted between the sides of a box or file drawer. Compatible only with 15¹/₄" (386 mm) W pedestals. Can also be used as a compressor.</i>			
	<i>For box drawer.</i>			
	12 ⁵ / ₈ x 3/4 x 4 ³ / ₈	320 x 18 x 112	KKDIV-5-_-_-	65
	<i>For file drawer.</i>			
	12 ⁵ / ₈ x 3/4 x 9 ³ / ₈	320 x 18 x 238	KKDIV-10-_-_-	76

	W x D x H (in)	W x D x H (mm)	Code	Price (\$)
 Sliding tray <i>Molded plastic on wood. Height adjustment 3", 3 1/2", 4" (76, 89, 102 mm). Locks in extended position. Black.</i>	28 3/8 x 15 x 3 1/2	721 x 381 x 89	KLGC-SKD27	329
 Pole-mounted support for flat screen <i>Is installed on the corner or side of a desk. Double-extension arm to support a screen. Sit-to-stand capability. Metal silver accent.</i>	20 3/4 x 6 1/2 x 17 3/4	527 x 167 x 450	KLGC-SUPECPLS	977
 Pole-mounted double support for flat screen <i>Is installed on the corner or side of a desk. 2 double-extension arms allow rotating and front-back movement of screens. Sit-to-stand capability. Silver accent.</i>	48 x 24 x 6 1/2	1200 x 610 x 167	KLGC-SUP2ECPLS	1,547
 Storage drawer <i>Made of black plastic.</i>	19 5/8 x 16 7/8 x 2 5/8	500 x 430 x 68	KKDR-20	264
 Suspended personal storage modules – 5 3/8" H <i>Is installed beneath a work surface. 5 3/8" H model can fit inside the 15 3/8" H model to create a two-compartment storage unit.</i>	9 3/8 x 15 x 5 3/8	245 x 383 x 136	KKASC-5-	330
 Suspended personal storage modules – 5 3/8" H <i>Metal, with laminate shelf.</i>	9 3/8 x 15 x 5 3/8	245 x 383 x 136	KKASCL-5-	400
Specify trim color. For model with laminate shelf, specify the laminate finish.				
 Hanging personal storage compartments – 15 3/8" H <i>Is installed beneath a work surface. 5 3/8" H model can fit inside the 15 3/8" H model to create a two-compartment storage unit.</i>	9 3/8 x 15 x 15 3/8	248 x 383 x 390	KKASC-15-	426
 Hanging personal storage compartments – 15 3/8" H <i>Metal, with laminate shelf.</i>	9 3/8 x 15 x 15 3/8	248 x 383 x 390	KKASCL-15-	495
Specify trim color. For model with laminate shelf, specify the laminate finish.				

PARADIGM Panel System >
Price Book > USA > January 2022

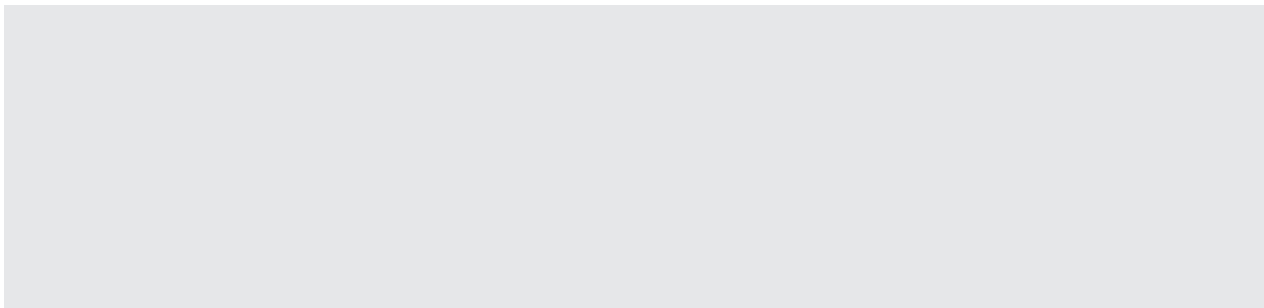

Office Furniture Solutions

Founded in 1956, Groupe Lacasse is a North American leader in the design, manufacture and service of a broad range of high-quality furniture products for all types of work environments. We have the experience, expertise and capability to deliver incomparable design, exceptional quality, optimum service and outstanding value in Office Furniture Solutions.



1-888-522-2773

www.grounelacasse.com